

MB MASTER-BILT®

Refrigeration Solutions



*Celebrating
70 Years of Service*

2008 PRICE LIST Cabinets & Merchandisers

REVISION A

Effective August 2, 2008 to February 15, 2009



See the inside front cover for a list of energy saving features and options on Master-Bilt equipment

MB MASTER-BILT®

Refrigeration Solutions



Because energy savings is an ever-increasing concern, Master-Bilt strives to make our equipment as efficient as possible. That's why we initiated our Energy Saver program to help you quickly identify features that serve your efficiency needs. Below is a list of features and options included in the program. Visit www.master-bilt.com/products/energy_saver.htm for more information.

Feature	Energy-Saving Function	Where Used
Demand defrost	Initiates electric defrost heaters only as needed	As part of the optional Master Controller electronic control system on walk-ins
Electric expansion valve	Highly efficient valve eliminates need to maintain a high head pressure (head pressure control valve eliminated also) allowing a lower head pressure and condensing temperature. A compressor operating at a lower condensing temperature yields higher capacity with less energy input.	As an integrated part of the optional Master Controller system for walk-ins
Reverse cycle defrost	A reverse cycle valve reverses the flow of high temperature refrigerant through evaporator coil, heating along its entire length and eliminating frost buildup. Results in an 80% decrease in defrost energy usage as well as a major reduction in defrost time.	An option used in conjunction with the Master Controller on walk-ins
Electronic lighting	T8 lighting with electronic ballasts uses less electricity than electromagnetic ballasts. Electronic lamps and ballasts run cooler reducing heat buildup in the refrigerated space.	Numerous cabinets and glass door walk-in freezers
Greenheat™ ASM-115 anti-sweat module	Modulates glass door and frame heaters that evaporate condensation. Heaters are only energized as needed.	An option on glass door walk-in freezers
MBWA-1 digital alarm/light management system	Door open alarm prevents door from being left open. Optional light management system automatically turns off lights after a programmed interval.	An option on walk-in coolers and freezers
Permanent Split Capacitor (PSC) Fan Motors	Amount of torque and current required to start PSC motors is low, making them more efficient. PSC motors run cooler, reducing heat load to refrigerated space which makes the compressor run less.	Optional on single phase walk-in unit coolers and standard on condensing units
5" and 6" thick panels	Thickness of panels produces a higher R-factor and energy efficiency required by California Energy Code	An option on walk-in coolers and freezers
MRS & DRS multi-compressor remote refrigeration systems	Since these systems are remote, the heat produced by multiple condensing units is removed from the kitchen or sales space reducing the air conditioning load and energy bill	Walk-ins and cabinets with remote refrigeration systems

GELATO MERCHANDISERS

GEL Series.....	2
-----------------	---

ICE CREAM, FROZEN FOOD & DAIRY MERCHANDISERS

FIP-40/FIP-50 Series.....	2
Coldin IG/IG-C Series	3
GT Series.....	4
DD/DD-L/DD-CG Series.....	5
DC Series	7
FLR Series	8
NEW BHC Series	9
IHC Series	10

OPEN DISPLAY MERCHANDISERS

QMVM/QMVM-L Series.....	11
MPM/QMPM Series.....	14
MDT Series	15

ICE MERCHANDISERS

NEW MODEL IM/IM-24 Series	17
--	----

GLASS DOOR MERCHANDISERS

BMG/BLG Series.....	18
TMG/TLG Series.....	19
BGR-14 Series	21
SMB Series	21

ENDLESS REMOTE GLASS DOOR MERCHANDISERS

BEM/BEL Series	22
TEM/TEL Series.....	23

DELI, DAIRY & SANDWICH MERCHANDISERS

DMS/DMS-F/DMS-L/DMS-LF Series.....	27
------------------------------------	----

MILK COOLERS

ATMC Series	28
ATMC-D Series	28
OMC Series.....	29
DOMC Series	29

HEATER/PROOFING CABINET

HP6A-LX Series.....	30
---------------------	----

FOODSERVICE REACH-INS

TAC/TAF Series	31
BSD Series.....	32

PREP UNITS & UNDERCOUNTERS

SPT/UC Series.....	33
PPT Series	33

SAMPLE CABINET WARRANTY	34
--------------------------------------	-----------

CONDENSING UNIT FEATURES	35
---------------------------------------	-----------

TERMS OF SALE & SPECIAL CONSIDERATIONS	36
---	-----------

Gelato Merchandisers

GEL SERIES Gelato Merchandisers



GEL-12



MODEL	LIST PRICE	DIMENSIONS (In Inches)			VOLTS*	AMPS**	UNIT H.P.	CAPACITY 5 LITER PANS	SHIP CU. FT.	SHIP WT. LB/KG
		L	D	H						
GEL-6	\$25,591	46 ⁵ / ₁₆	44 ¹ / ₂	53 ³ / ₈	208-230	9.0	1	12	93.0	900/409
GEL-9	\$30,057	65 ¹⁵ / ₁₆	44 ¹ / ₂	53 ³ / ₈	208-230	13.1	***	18	127.0	1100/500
GEL-12	\$37,040	85 ¹ / ₂	44 ¹ / ₂	53 ³ / ₈	208-230	13.8	***	24	161.0	1300/591

*Note: 208-230/60/1 also requires neutral and safety ground wire.

**Standard electric condensate evaporator pan requires a dedicated 15 amp, 120 volt circuit.

***Refrigeration system contains two 1 HP compressors.

GEL SERIES Options

PART NO.	LIST PRICE	DESCRIPTION	SHIP WT. LB/KG
CASTERS			
A016A11140	\$141	Set of 4, 2 ¹ / ₂ " dia. for GEL-6 and GEL-9	4/2
A018A11140	\$202	Set of 6, 2 ¹ / ₂ " dia. for GEL-12	5/2
STAINLESS STEEL FIVE LITER FOOD PANS (PRICE EACH)			
44-01050	\$75	GEL-6 holds 24 (12 per level), GEL-9 holds 36 (18 per level), GEL-12 holds 48 (24 per level)	3/1
STAINLESS STEEL 1/3 SIZE 4" DEEP FOOD PANS (PRICE EACH)			
44-01054	\$75	GEL-6 holds 20 (10 per level), GEL-9 holds 32 (16 per level), GEL-12 holds 44 (22 per level)	3/1
STAINLESS STEEL 1/3 SIZE 6" DEEP FOOD PANS (PRICE EACH)			
44-01055	\$75	GEL-6 holds 10, GEL-9 holds 16, GEL-12 holds 22	3/1
DIPPER WELL			
A060-20400	\$462	With installation kit for all GEL models	4/2

Add \$250 net for custom paint upcharge on front, rear and/or ends of GEL models.

Ice Cream, Frozen Food & Dairy Merchandisers

FIP-40/FIP-50 SERIES Ice Cream & Novelty Display Merchandisers



FIP-40



FIP-50

MODEL	LIST PRICE	DIMENSIONS (In Inches)			VOLTS	AMPS	UNIT H.P.	CAPACITY CU. FT.	SHIP CU. FT.	SHIP WT. LB/KG
		L	D	H						
FIP-40	\$10,439	40	31	50 ³ / ₁₆	115	13.6	3/4	11.8	46.4	427/194
FIP-50	\$11,093	60	31	50	115	13.4	3/4	18.1	87.0	640/291

FIP SERIES Options

PART NO.	LIST PRICE	DESCRIPTION	SHIP WT. LB/KG
EXTRA SHELF			
33-01721	\$143	Extra wire shelf for FIP-40	12/5
CASTERS			
A039-11140	\$144	Set of four, 2" dia. for FIP-40	4/2
A070-11140	\$269	Set of four, 3" dia. for FIP-50	6/3



(Both models) (FIP-40 only) (FIP-50 only)

Ice Cream, Frozen Food & Dairy Merchandisers

COLDIN™ IG/IG-C SERIES Display Freezers



IG-408



IG-409C



MODEL	LIST PRICE	DIMENSIONS (In Inches)			VOLTS	AMPS	UNIT H.P.	INTERNAL VOLUME CU. FT.*	SHIP CU. FT.	SHIP WT. LB/KG
		L	D	H						
STANDARD FLAT LID										
IG-208	\$1597	29 ⁹ / ₁₆	25 ⁷ / ₈	36 ¹ / ₂	115	3.4	1/4	6.1	19.4	101/46
IG-308	\$1865	41	25 ⁷ / ₈	36 ¹ / ₂	115	4.2	1/4	9.5	27.1	119/54
IG-408	\$2081	51 ⁹ / ₁₆	25 ⁷ / ₈	36 ¹ / ₂	115	5.3	1/4	12.5	34.9	136/62
IG-508	\$2381	60 ¹ / ₂	25 ⁷ / ₈	36 ¹ / ₂	115	6.2	1/4	14.1	40.3	163/74
IG-608	\$2619	69 ³ / ₄	25 ⁷ / ₈	36 ¹ / ₂	115	5.0	1/2	16.7	45.0	183/83
CURVED LID										
IG-209C	\$1929	29 ⁹ / ₁₆	25 ⁷ / ₈	36 ¹ / ₂	115	3.4	1/4	5.0	19.4	99/45
IG-309C	\$2264	41	25 ⁷ / ₈	36 ¹ / ₂	115	3.7	1/4	7.8	26.3	128/58
IG-409C	\$2567	51 ⁹ / ₁₆	25 ⁷ / ₈	36 ¹ / ₂	115	5.6	1/4	10.4	34.1	136/62
IG-509C	\$2886	60 ¹ / ₂	25 ⁷ / ₈	36 ¹ / ₂	115	6.0	1/2	11.5	39.5	183/83
IG-609C	\$3062	69 ³ / ₄	25 ⁷ / ₈	36 ¹ / ₂	115	6.0	1/2	13.6	44.2	202/92

*Measured at product load line.

COLDIN SERIES Options

PART NO.	LIST PRICE	DESCRIPTION	SHIP WT. LB/KG
EXTRA BASKETS FOR STANDARD FLAT LID MODELS			
70-00100	\$42	210 mm basket for Coldin flat lid models (each)	7/3
70-00101	\$42	285 mm basket for Coldin flat lid models (each)	7/3
EXTRA BASKETS FOR CURVED LID MODELS			
70-00105	\$42	210 mm basket for Coldin curved lid models (each)	7/3
70-00102	\$42	285 mm basket for Coldin curved lid models (each)	7/3
EXTRA BASKET DIVIDERS			
70-00150	\$15	Horizontal divider for Coldin 210 mm basket (each)	2/1
70-00151	\$15	Horizontal divider for Coldin 285 mm basket (each)	2/1
70-00152	\$15	Vertical divider for Coldin 210 mm and 285 mm baskets (each)	2/1
REPLACEMENT THERMOMETER			
70-00002	\$15	For all Coldin models (each)	2/1

Consult factory for pricing and availability on lighted canopies, sneeze guards and solid lids.

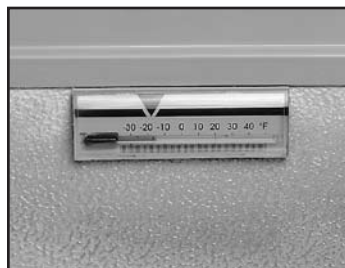

COLDIN THERMOMETER

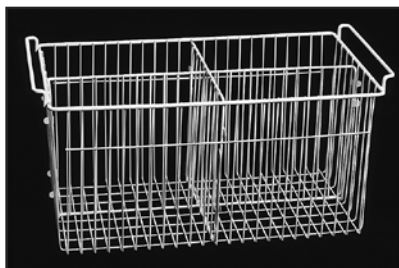

COLDIN BASKET WITH DIVIDERS

Ice Cream, Frozen Food & Dairy Merchandisers

GT SERIES Low Temp Horizontal Display Merchandisers



GT-60

MODEL	LIST PRICE	DIMENSIONS (In Inches)			VOLTS	AMPS	UNIT H.P.	CAPACITY CU. FT.	SHIP CU. FT.	SHIP WT. LB/KG
		L	D	H						
GT-30	\$7646	36 ^{15/16}	32 ^{3/16}	39 ^{3/8}	115	9.9	1/2	7.2	43.0	435/198
GT-40	\$7787	48 ^{5/8}	32 ^{3/16}	39 ^{3/8}	115	9.9	1/2	10.0	50.0	470/214
GT-50	\$8558	60 ^{3/8}	32 ^{3/16}	39 ^{3/8}	115	10.1	3/4	13.5	60.0	530/241
GT-60	\$8778	72 ^{5/16}	32 ^{3/16}	39 ^{3/8}	115	10.3	3/4	17.4	71.0	585/266
GT-80	\$10,229	95 ^{15/16}	32 ^{3/16}	39 ^{3/8}	115	12.0	3/4	25.5	92.0	705/320



GT SERIES Options

PART NO.	LIST PRICE	DESCRIPTION	SHIP WT. LB/KG
CASTERS			
A027-11240	\$116	Set of 4, 2" diameter for GT-30 through GT-60	8/4
A033-11240	\$173	Set of 6, 2" diameter for GT-80	10/5
LOAD LEVEL SHELVES			
A027-18127	\$333	For GT-30	7/3
A029-18127	\$343	For GT-40	20/9
A030-18127	\$409	For GT-50	20/9
A031-18127	\$426	For GT-60	25/11
A033-18127	\$493	For GT-80	35/16
LID LOCKING KITS - LESS LOCKS			
A027-11129	\$68	For GT-30	1/0.4
A029-11129	\$87	For GT-40 through GT-60	1/0.4
A032-11129	\$118	For GT-80	1/0.4
NOVELTY BASKETS - WELDED WIRE WHITE EPOXY-COATED			
33-01405	\$46	9.125" x 12" x 7.125" deep	5/2
SACK RACK - 48"L X 17.5"H X 3"D			
A030-20400	\$212	For GT-50 through GT-80	27/12
SUPERSTRUCTURES			
A027-20200	\$1142	For GT-30	100/45
A029-20200	\$1270	For GT-40	100/45
A030-20200	\$1514	For GT-50	112/51
A031-20200	\$1631	For GT-60	140/64
A033-20200	\$1948	For GT-80	173/79



GT SACK RACK



GT LOAD LEVEL SHELF



GT LID LOCKING KIT

Ice Cream, Frozen Food & Dairy Merchandisers

DD/DD-L/DD-CG SERIES

Deluxe Ice Cream Dipping/Display Merchandisers



DD-46

MODEL	DIMENSIONS (In Inches)			VOLTS	AMPS	UNIT H.P.	CAPACITY DISPLAY/ STORAGE**	SHIP CU. FT.	SHIP WT. LB/KG
	L	D	H						
DD-26/26L/26CG	26 ¹ / ₂	27 ³ / ₄	*	115	7.4	1/3	4/0	38.0	240/109
DD-46/46L/46CG	47 ³ / ₄	27 ³ / ₄	*	115	7.5	1/2	8/4	54.0	370/168
DD-66/66L/66CG	69 ¹ / ₄	27 ³ / ₄	*	115	9.7	1/2	12/8	76.0	495/225
DD-88/88L/88CG	90 ³ / ₄	27 ³ / ₄	*	115	11.5	3/4	16/12	97.0	600/273

*Height of standard and low glass models: 50", curved glass models: 52"

**Capacity measured in 9¹/₂" diameter, 3 gallon cans.



DD-46L

STANDARD MODELS

MODEL	LIST PRICE
DD-26	\$4978
DD-46	\$5881
DD-66	\$8168
DD-88	\$9070

LOW GLASS MODELS

MODEL	LIST PRICE
DD-26L	\$5976
DD-46L	\$6858
DD-66L	\$9704
DD-88L	\$10,977

CURVED GLASS MODELS

MODEL	LIST PRICE
DD-26CG	\$5747
DD-46CG	\$7159
DD-66CG	\$9115
DD-88CG	\$10,035



DD-46CG

Optional rear service doors available. Add \$326 to list price of DD-46 models and \$651 for DD-66 and DD-88 models. DD-46 models require one door, DD-66 and DD-88 require two.

DD/DD-L/DD-CG SERIES Options

PART NO.	LIST PRICE	DESCRIPTION	SHIP WT. LB/KG
		CAN HOLDERS - INCLUDES WHITE CAN COVERS	
A059-20300	\$402	For DD-26/DD-26L/DD-26CG	5/2
A062-20300	\$602	For DD-46/DD-46L/DD-46CG	8/4
A060-20300	\$814	For DD-66/DD-66L/DD-66CG	10/5
A061-20300	\$1007	For DD-88/DD-88L/DD-88CG	14/6
		CAN COVERS	
44-00984	\$16	Clear (each)	2/0.9
44-00973	\$8	White (each)	2/0.9
		DIPPER WELL	
A060-20400	\$462	With installation kit for all DD, DD-L and DD-CG models	4/2
		FROST SHIELDS (A MASTER-BILT EXCLUSIVE)	
A059-11150	\$257	For DD-26/DD-26CG	5/2
A062-11150	\$321	For DD-46/DD-46CG	7/3
A060-11150	\$465	For DD-66/DD-66CG	8/4
A061-11150	\$474	For DD-88/DD-88CG	10/5
A059-11250	\$257	For DD-26L	5/2
A062-11250	\$321	For DD-46L	7/3
A060-11250	\$465	For DD-66L	8/4
A061-11250	\$474	For DD-88L	10/5



CONTINUED ON NEXT PAGE

Ice Cream, Frozen Food & Dairy Merchandisers

DD/DD-L/DD-CG SERIES Options (cont.)

PART NO.	LIST PRICE	DESCRIPTION	SHIP WT. LB/KG
		CASTERS	
A059-11340	\$119	Set of 4, 2" diameter for DD-26/DD-26L/DD-26CG and DD-46/DD-46L/DD-46CG	4/2
A060-11340	\$175	Set of 6, 2" diameter for DD-66/DD-66L/DD-66CG and DD-88/DD-88L/DD-88CG	5/2
		LEG KITS	
A062-11270	\$148	6" leg kit for DD-26/DD-26L/DD-26CG and DD-46/DD-46L/DD-46CG	18/8
A061-11270	\$213	6" leg kit for DD-66/DD-66L/DD-66CG and DD-88/DD-88L/DD-88CG	26/12
		LID LOCKING KITS - LESS LOCKS	
A059-11129	\$75	For DD-26/DD-26L/DD-26CG and DD-46/DD-46L/DD-46CG	2/1
A060-11129	\$120	For DD-66/DD-66L/DD-66CG and DD-88/DD-88L/DD-88CG	3/1
		DDN FLAVOR TAGS	
A062-20225	\$13	For all DD/DD-CG models	1/.5
		ICE CREAM PAN RACK ASSEMBLY (PANS NOT INCLUDED)	
A059-18040	\$307	For DD-26/DD-26CG	15/7
A062-18040	\$577	For DD-46/DD-46CG	17/8
A060-18040	\$713	For DD-66/DD-66CG	26/12
A061-18040	\$761	For DD-88/DD-88CG	31/14
A059-S9040	\$388	For DD-26L	17/8
A062-S9040	\$498	For DD-46L	19/9
A060-S9040	\$608	For DD-66L	35/16
A061-S9040	\$688	For DD-88L	40/18



DD FROST SHIELDS

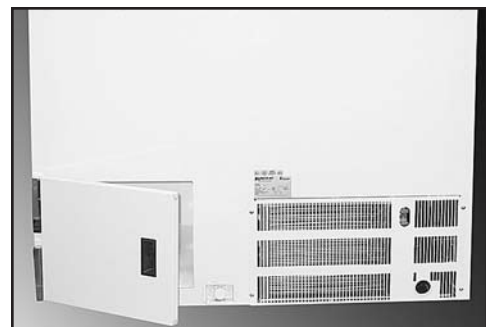

DD REAR SERVICE DOOR



DD CAN HOLDERS

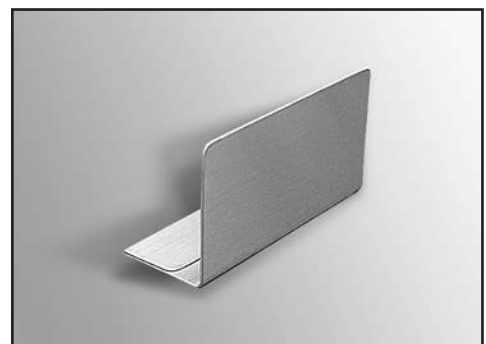

DD FLAVOR TAG

Ice Cream, Frozen Food & Dairy Merchandisers

DC SERIES Conventional Ice Cream Storage/Dipping Cabinets

Stainless Steel Exterior Finish Available



DC-8D



DC-2S

UL **NSF**
 (C-UL listing for all models except DC-12D)

MODEL	LIST PRICE	STAINLESS EXTERIOR MODEL	STAINLESS EXTERIOR LIST PRICE	DIMENSIONS (In Inches)			VOLTS	AMPS	UNIT H.P.	CAPACITY DISPLAY/STORAGE*	SHIP CU. FT.	SHIP WT. LB/KG
				L	D	H						
DC-2S	\$3817	DC-2SSE	\$4310	31 ⁷ / ₈	21 ¹ / ₈	34 ¹ / ₈	115	5.7	1/4	2/1	19.0	195/89
DC-4S	\$4479	DC-4SSE	\$5483	54	21 ¹ / ₈	34 ¹ / ₈	115	5.7	1/4	5/4	36.0	280/127
DC-4D	\$4011	DC-4DSE	\$4932	30 ⁵ / ₈	30 ¹ / ₈	34 ¹ / ₈	115	5.7	1/4	5/2	27.0	220/100
DC-6D	\$4654	DC-6DSE	\$5484	43	30 ¹ / ₈	34 ¹ / ₈	115	5.7	1/4	8/5	39.0	275/125
DC-8D	\$4932	DC-8DSE	\$5835	54	30 ¹ / ₈	34 ¹ / ₈	115	7.3	1/3	11/8	47.0	365/164
DC-10D	\$5801	DC-10DSE	\$6276	66 ⁵ / ₈	30 ¹ / ₈	34 ¹ / ₈	115	7.3	1/3	14/11	59.0	430/195
DC-12D	\$7500	DC-12DSE	\$8762	84 ⁵ / ₈	30 ¹ / ₈	34 ¹ / ₈	115	7.5	1/3**	18/15	71.0	490/223

*Capacity measured in 3 gallon cans.

**DC-12D contains semi-hermetic compressor.

DC SERIES Options

PART NO.	LIST PRICE	DESCRIPTION	SHIP WT. LB/KG
CASTERS			
A039-11140	\$144	Set of 4, 2" diameter casters for DC-2S, DC-4S, DC-4D, DC-6D and DC-8D	4/2
A044-11140	\$207	Set of 6, 2" diameter for for DC-10D and DC-12D	5/2
LEG KITS			
A039-11170	\$143	6" leg kit for DC-2S, DC-4S, DC-4D, DC-6D and DC-8D	18/8
A044-11170	\$191	6" leg kit for DC-10D and DC-12D	26/12
LID LOCKING KITS - LESS LOCKS			
A041-11129	\$104	For DC-2S and DC-4D	3/1
A051-11229	\$342	For DC-4S	5/2
A043-11129	\$190	For DC-6D and DC-8D	5/2
A044-11129	\$314	For DC-10D and DC-12D	6/3
LIDS			
44-00470	\$320	Single lid for DC models	5/2
44-00471	\$418	Double lid for DC models	9/4
LOAD LEVEL SHELVES			
A039-18127	\$224	Load level shelf for DC-2S	*
A040-18127	\$396	Load level shelf for DC-4S	*
A041-18127	\$246	Load level shelf for DC-4D	16/7
A042-18127	\$411	Load level shelf for DC-6D	20/9
A043-18127	\$421	Load level shelf for DC-8D	22/10
A044-18127	\$557	Load level shelf for DC-10D	24/11
A045-18127	\$644	Load level shelf for DC-12D	*
DIPPER WELL			
A060-20400	\$462	With installation kit for all DC models	4/2

*Consult factory.



DC LID LOCKING KIT

Ice Cream, Frozen Food & Dairy Merchandisers

FLR SERIES Flavorail Ice Cream Dipping Cabinets

Stainless Steel Exterior Finish Available



FLR-80



Standard FLR cabinets do not include optional pumps and jars.

MODEL	LIST PRICE	STAINLESS EXTERIOR MODEL	STAINLESS EXTERIOR LIST PRICE	DIMENSIONS (In Inches)			VOLTS	AMPS	UNIT H.P.	CAPACITY DISPLAY/STORAGE*	SHIP CU. FT.	SHIP WT. LB/KG
				L	D	H						
FLR-60	\$5614	FLR-60SE	\$6,216	43	30 ¹ / ₈	38 ¹ / ₄	115	5.7	1/4	5/7	46.0	300/136
FLR-80	\$5883	FLR-80SE	\$6,566	54	30 ¹ / ₈	38 ¹ / ₄	115	7.3	1/3	6/11	57.0	340/155

*Capacity measured in 3 gallon cans.

FLR SERIES Options

PART NO.	LIST PRICE	DESCRIPTION	SHIP WT. LB/KG
PUMP AND JAR ASSEMBLIES			
A050-11150	\$924	For FLR-60: 1 chocolate pump, 1 syrup pump, 3 jars with lids and spoons	12/5
A051-11150	\$1414	For FLR-80: 1 chocolate pump, 2 syrup pumps, 6 jars with lids and spoons, 1 spoon holder	20/9
LID LOCKING KITS - LESS LOCKS			
A050-11229	\$245	For FLR-60	5/2
A051-11229	\$342	For FLR-80	5/2
CASTERS			
A039-11140	\$144	Set of 4, 2" dia. for FLR-60 and FLR-80	4/2
LEG KITS			
A039-11170	\$143	6" leg kit for FLR models	18/8
INDIVIDUAL PARTS			
44-00558	\$208	Chocolate pump	3/1
44-00559	\$160	Syrup pump	3/1
44-00561	\$55	Spoon holder jar	3/1
44-00562	\$32	Fruit jar (does not include hinged lid or ladle)	3/1
44-00560	\$41	Syrup jar (does not include hinged lid or ladle)	3/1
44-00565	\$82	Hinged lid (for individual fruit jar)	1/0.4
44-00563	\$25	Ladle	1/0.4
DIPPER WELL			
A060-20400	\$462	With installation kit for all FLR models	4/2



FLR-80 PUMPS AND JARS

Ice Cream, Frozen Food & Dairy Merchandisers

BHC SERIES Bottom Mounted Ice Cream Hardening & Holding Cabinets

NEW



BHC-27



PENDING

SELF-CONTAINED

MODEL	LIST PRICE	DIMENSIONS (In Inches)			VOLTS	AMPS	UNIT H.P.	CAPACITY 3 GAL. CANS	USABLE INTERIOR CAPACITY CU. FT.	SHIP WT. LB/KG
		L	D	H						
BHC-27	\$8873	31	36 ¹ / ₂	79	115	12.0	3/4	24	20.5	630/286
BHC-27E**	\$9005	31	36 ¹ / ₂	79	230**	6.0	3/4	24	20.5	630/286
BHC-48E**	\$11,985	52	36 ¹ / ₂	79	230**	9.0	2	48	36.5	880/400

**230 volt models operate on 208-230/60/1 and also on 220/50/1.

REMOTE (Less condensing unit)*

MODEL	LIST PRICE	CASE AMP DRAW 230V			NORMAL AMBIENT UNIT UP TO 100°F	HIGH AMBIENT UNIT 100°F TO 120°F	SHIP WT. LB/KG
		CASE HEATER	EVAP. FANS	DEFROST			
BHC-48R	\$10,192	0.7	.5	5.8	MHLZ0091 (B or C)	MHLZ0121 (B or C)	CONTACT FACTORY

BHC cabinets operate on a minimum of 208 volts. Part no. 39-01087 voltage boosting transformer (see options below) must be used when the supply voltage is less than 208 volts. This transformer is shipped loose.

REMOTE CONDENSING UNIT SPECIFICATIONS (Standard features listed on p. 35)*

MODEL	LIST PRICE	VOLTAGE	REFRIG.	BTU RATING AT +20°F SUCTION +35°F CABINET*	BTU RATING AT -10°F SUCTION 0°F CABINET*	BTU RATING AT -20°F SUCTION -10°F CABINET*	BTU RATING AT -30°F SUCTION -20°F CABINET*	ELECTRICAL		SHIP WT. LB/KG
								MCA	MOP	
MHLZ0091B	\$4087	208-230/60/1	R-404A	N/A	12,480	9133	6193	26	40	260/118
MHLZ0091C	\$3982	200-230/60/3	R-404A	N/A	12,314	9230	6484	19	25	245/111
MHLZ0121B	\$4279	208-230/60/1	R-404A	N/A	15,035	11,559	8077	30	45	260/118
MHLZ0121C	\$4236	200-230/60/3	R-404A	N/A	14,963	11,596	8402	21	30	260/118

*BTUs rated at 90°F air entering condenser.

BHC SERIES Options

PART NO.	LIST PRICE	DESCRIPTION	SHIP WT. LB/KG
		CASTERS	
A039-11140	\$144	Set of 4, 2" dia. for BHC-27, BHC-27E, BHC-48E	4/2
		LEG KITS	
A200-11170	\$430	6" kit for for BHC-27, BHC-27E, BHC-48E	20/9
		EXTRA CONVENTIONAL SHELVING	
33-01763	\$111	For BHC-27 and BHC-27E	7/3
33-01875	\$183	For BHC-48E	8/4
		EXTRA SHELF CLIPS	
33-01011	\$4	For all BHC models	2/1
		EXTRA CONVENTIONAL SHELVING - BLACK PAINTED UPCHARGE	
		\$20 each shelf for all BHC models	
		VOLTAGE BOOSTING TRANSFORMER	
39-01087	\$548	For BHC-27E and BHC-48E models	14/6

Ice Cream, Frozen Food & Dairy Merchandisers

IHC SERIES Top Mounted Ice Cream Hardening & Holding Cabinets



IHC-48



SELF-CONTAINED

MODEL	LIST PRICE	DIMENSIONS (In Inches)			VOLTS	AMPS	UNIT H.P.	NEMA PLUG TYPE	CAPACI- TY 3 GAL. CANS	USABLE INTERIOR CAPACITY CU. FT.	SHIP WT. LB/KG
		L	D	H*							
IHC-27	\$11,477	31	36	82	208-230	7.4	1	6-15P	20	19.0	490/223
IHC-48	\$14,427	52	36	82	208-230	11.5	1 1/2	6-15P	43	34.5	690/314

*Height includes 6" - 7" adjustable legs.

REMOTE (Less condensing unit)*

MODEL	LIST PRICE	CASE AMP DRAW			CONDENSING UNIT*	SHIP WT. LB/KG
		230V				
		CASE HEATER	EVAP. FANS	DEFROST		
IHC-48R	\$11,097	2.3	0.5	6.5	MCLZ0101(B or C)	560/255

*Remote condensing units sized for 100°F ambient. Consult factory for higher ambient conditions.

IHC cabinets operate on a minimum of 208 volts. Part no. 39-01087 voltage boosting transformer (see options below) must be used when the supply voltage is less than 208 volts. This transformer is shipped loose.

REMOTE CONDENSING UNIT SPECIFICATIONS (Standard features listed on p. 35)*

MODEL	LIST PRICE	VOLTAGE	REFRIG.	BTU RATING AT +20°F SUCTION +35°F CABINET*	BTU RATING AT -10°F SUCTION 0°F CABINET*	BTU RATING AT -20°F SUCTION -10°F CABINET*	BTU RATING AT -30°F SUCTION -20°F CABINET*	ELECTRICAL		SHIP WT. LB/KG
								MCA	MOP	
MCLZ0101B	\$7281	208-230/60/1	R-404A	N/A	11,804	9104	6999	24	35	330/150
MCLZ0101C	\$6912	208-230/60/3	R-404A	N/A	11,678	8755	6169	19	20	330/150

*BTUs rated at 90°F air entering condenser.

IHC SERIES Options

PART NO.	LIST PRICE	DESCRIPTION	SHIP WT. LB/KG
		CASTERS	
A297-11140	\$613	Set of 4, 5" dia. casters for IHC-27 and IHC-48	38/17
		CANTILEVER SHELVES - WELDED WIRE, GRAY EPOXY-COATED, TWO-POSITION	
33-01519	\$111	Extra cantilever shelf for IHC-27	7/3
33-01518	\$111	Extra cantilever shelf for IHC-48	7/3
		PAN RACK	
02-70976	\$623	For both IHC models (per section)	25/11
		VOLTAGE BOOSTING TRANSFORMER	
39-01087	\$548	For both IHC models	14/6

Open Display Merchandisers

QMVM/QMVM-L SERIES Quantum Series Medium Temp Open Display Merchandisers

QMVM-36 & QMVM-48 models now with cord and plug.

Stainless Steel Interior & Exterior Finish Available



QMVM-48

QMVM-36L



NSF/ANSI 7

SELF-CONTAINED

MODEL	LIST PRICE	STAINLESS INTERIOR/ EXTERIOR MODEL	STAINLESS INTERIOR/ EXTERIOR LIST PRICE	DIMENSIONS (In Inches)			VOLTS	AMPS	UNIT H.P.	CAP. CU. FT.	SHIP CU. FT.	SHIP WT. LB/KG
				L	D	H						
STANDARD												
QMVM-36E	\$11,967	QMVM-36ESS	\$16,347	36	30	81	208-230	13.5	1	13.6	89.0	525/239
QMVM-48E	\$12,295	QMVM-48ESS	\$18,123	48	30	81	208-230	16.1	1	20.4	107.0	640/291
QMVM-72E	\$14,184	QMVM-72ESS	\$21,377	72	30	81	115/208-230	3.7/13.7	1 1/2	31.5	152.0	860/391
LOW PROFILE												
QMVM-36L	\$9361	QMVM-36LSS	\$14,340	36	30	60	115	14.8	1/2	11.2	67.0	490/223
QMVM-48L	\$10,409	QMVM-48LSS	\$15,036	48	30	60	115	14.9	3/4	15.4	81.0	580/264

REMOTE (Less condensing unit)*

MODEL	LIST PRICE	CASE AMP DRAW			CONDENSING UNIT*	SHIP WT. LB/KG
		115V LIGHTS	208-230V EVAP. FANS	230V DEFROST		
QMVM-48R	\$10,293	3.0	0.9	3.5	MHHZ0191(B or C)	535/243
QMVM-72R	\$12,129	4.3	1.4	4.8	MHHZ0221(B or C)	720/327

*Remote condensing units sized for 100°F ambient. Consult factory for higher ambient conditions.

NOTE: QMVM & QMVM-L models require floor drain. If drain is unavailable, condensate evaporator drain pan option is necessary, see p. 12 for details.

REMOTE CONDENSING UNIT SPECIFICATIONS (Standard features listed on p. 35)*

MODEL	LIST PRICE	VOLTAGE	REFRIG.	BTU RATING AT +20°F SUCTION +35°F CABINET*	BTU RATING AT -10°F SUCTION 0°F CABINET*	BTU RATING AT -20°F SUCTION -10°F CABINET*	BTU RATING AT -30°F SUCTION -20°F CABINET*	ELECTRICAL		SHIP WT. LB/KG
								MCA	MOP	
MHHZ0191B	\$3932	208-230/60/1	R-404A	14,826	N/A	N/A	N/A	20	30	360/164
MHHZ0191C	\$4230	200-230/60/3	R-404A	14,661	N/A	N/A	N/A	19	20	360/164
MHHZ0221B	\$4065	208-230/60/1	R-404A	16,726	N/A	N/A	N/A	23	30	360/164
MHHZ0221C	\$4280	200-230/60/3	R-404A	16,491	N/A	N/A	N/A	23	25	360/164

*BTUs rated at 90°F air entering condenser.

Open Display Merchandisers

QMVM/QMVM-L SERIES Options

PART NO.	LIST PRICE	DESCRIPTION	SHIP WT. LB/KG
		PRODUCT HOOK ASSEMBLY	
A068-15000	\$98	For QMVM-36 & QMVM-36L [(1) 33.5" bar, (2) shelf brackets, and (8) 6" hooks]	8/4
A075-15000	\$111	For QMVM-48 & QMVM-48L [(1) 43" bar, (2) shelf brackets, and (10) 6" hooks]	5/2
A076-15000	\$124	For QMVM-72 [(1) 33.5" bar, (2) shelf brackets, and (8) 6" hooks]	4/2
44-01016	\$4	Extra 6" hooks (each)	5/2
		CASTERS	
A075-11140	\$293	Set of 4, 3" dia. for QMVM-36, QMVM-36L, QMVM-48 and QMVM-48L	16/7
A076-11140	\$429	Set of 6, 3" dia. for QMVM-72	24/11
		CONDENSATE PUMP	
61-00529	\$372	For QMVM-72	12/5
		CONDENSATE EVAPORATOR DRAIN PAN (MUST BE FIELD INSTALLED & REQUIRES DEDICATED 15A, 120V CIRCUIT)	
17-09287	\$555	For QMVM-36 and QMVM-36L	8/4
17-09264	\$624	For QMVM-48, QMVM-48L and QMVM-72	15/7
		EXTRA SHELVES – WHITE	
A068DW214*	\$459	14" lighted shelf for QMVM-36* (full shelf) EXTENDED HOOD VERSION ONLY	15/7
A068DW114*	\$241	14" non-lighted shelf for QMVM-36 and QMVM-36L* (full shelf) EXTENDED HOOD VERSION ONLY	11/5
A075DW214*	\$534	14" lighted shelf for QMVM-48* (full shelf) EXTENDED HOOD VERSION ONLY	20/9
A075DW114*	\$420	14" non-lighted shelf for QMVM-48 and QMVM-48L* (full shelf) EXTENDED HOOD VERSION ONLY	**
A076DW214*	\$464	14" lighted shelf for QMVM-72* (half shelf) EXTENDED HOOD VERSION ONLY	**
A076DW114*	\$314	14" non-lighted shelf for QMVM-72* (half shelf) EXTENDED HOOD VERSION ONLY	15/7
		EXTRA SHELVES – BLACK PAINTED	
A068DB214*	\$476	14" lighted shelf for QMVM-36* (full shelf) EXTENDED HOOD VERSION ONLY	15/7
A068DB114*	\$258	14" non-lighted shelf for QMVM-36 and QMVM-36L* (full shelf) EXTENDED HOOD VERSION ONLY	11/5
A075DB214*	\$550	14" lighted shelf for QMVM-48* (full shelf) EXTENDED HOOD VERSION ONLY	20/9
A075DB114*	\$436	14" non-lighted shelf for QMVM-48 and QMVM-48L* (full shelf) EXTENDED HOOD VERSION ONLY	**
A076DB214*	\$481	14" lighted shelf for QMVM-72* (half shelf) EXTENDED HOOD VERSION ONLY	**
A076DB114*	\$330	14" non-lighted shelf for QMVM-72* (half shelf) EXTENDED HOOD VERSION ONLY	15/7
		EXTRA SHELVES – STAINLESS STEEL	
A068-S214	\$800	14" lighted shelf for QMVM-36* (full shelf) EXTENDED HOOD VERSION ONLY	15/7
A075-S214	\$878	14" lighted shelf for QMVM-48* (full shelf) EXTENDED HOOD VERSION ONLY	20/9
		VINYL NIGHT CURTAIN – FACTORY INSTALLED (FITS "EXTENDED HOOD" MODELS ONLY)	
A068D11131	\$323	For QMVM-36	**
A075D11131	\$339	For QMVM-48	**
A076D11131	\$663	For QMVM-72	**
		VINYL NIGHT CURTAIN – FIELD INSTALLED (FITS "EXTENDED HOOD" MODELS ONLY)	
A068D11231	\$231	For QMVM-36	**
A075D11231	\$243	For QMVM-48	**
A076D11231	\$446	For QMVM-72	**
		LOCKING METAL NIGHT CURTAIN – LESS LOCK	
A068D16000	\$231	Locking metal night curtain for QMVM-36	4/2
A075D16000	\$265	Locking metal night curtain for QMVM-48	5/2
A076D16000	\$453	Locking metal night curtain for QMVM-72	7/3

*One extra shelf per side only. **Consult factory.

Open Display Merchandisers

QMVM/QMVM-L/QMPM SERIES Bumper Kits

PART NO.	LIST PRICE	DESCRIPTION	SHIP WT. LB/KG
		BUMPER KITS	
A071-00100	\$142	White bumper for QMPM-36, QMVM-36 and QMVM-36L	5/2
A071-00200	\$142	Red bumper for QMPM-36, QMVM-36 and QMVM-36L	5/2
A071-00300	\$142	Green bumper for QMPM-36, QMVM-36 and QMVM-36L	5/2
A071-00400	\$142	Blue bumper for QMPM-36, QMVM-36 and QMVM-36L	5/2
A071-00500	\$142	Brown bumper for QMPM-36, QMVM-36 and QMVM-36L	5/2
A071-00600	\$142	Black bumper for QMPM-36, QMVM-36 and QMVM-36L	5/2
A072-00100	\$149	White bumper for QMPM-48, QMVM-48 and QMVM-48L	5/2
A072-00200	\$149	Red bumper for QMPM-48, QMVM-48 and QMVM-48L	5/2
A072-00300	\$149	Green bumper for QMPM-48, QMVM-48 and QMVM-48L	5/2
A072-00400	\$149	Blue bumper for QMPM-48, QMVM-48 and QMVM-48L	5/2
A072-00500	\$149	Brown bumper for QMPM-48, QMVM-48 and QMVM-48L	5/2
A072-00600	\$149	Black bumper for QMPM-48, QMVM-48 and QMVM-48L	5/2
A073-00100	\$175	White bumper for QMPM-72 and QMVM-72	5/2
A073-00200	\$175	Red bumper for QMPM-72 and QMVM-72	5/2
A073-00300	\$175	Green bumper for QMPM-72 and QMVM-72	5/2
A073-00400	\$175	Blue bumper for QMPM-72 and QMVM-72	5/2
A073-00500	\$175	Brown bumper for QMPM-72 and QMVM-72	5/2
A073-00600	\$175	Black bumper for QMPM-72 and QMVM-72	5/2



QMVM, QMVM-L AND QMPM SERIES BUMPERS

Open Display Merchandisers

MPM/QMPM SERIES Medium Temp Open Display Merchandisers

Stainless Steel
Interior & Exterior
Finish Available



MPM-48



QMPM-48



MODEL	LIST PRICE	STAINLESS INTERIOR/ EXTERIOR MODEL	STAINLESS INTERIOR/ EXTERIOR LIST PRICE	DIMENSIONS (In Inches)			VOLTS	AMPS	UNIT H.P.	CAP. CU. FT.	SHIP CU. FT.	SHIP WT. LB/KG
				L	D	H						
STANDARD												
MPM-36	\$6826	MPM-36SS	\$9578	36	30 ¹ / ₂	43 ¹ / ₄	115	10.3	1/3	3.7	41.0	310/141
MPM-48	\$8092	MPM-48SS	\$10,691	48	30 ¹ / ₂	43 ¹ / ₄	115	15.5	1/2	5.1	53.0	410/220
MPM-72	\$9224	MPM-72SS	\$13,730	72	30 ¹ / ₂	43 ¹ / ₄	115/115*	15.8/10.4*	3/4	7.9	86.0	590/268
QUANTUM SERIES												
QMPM-36	\$7194	QMPM-36SS	\$10,154	36	30	43 ¹ / ₄	115	10.3	1/3	3.7	42.0	310/141
QMPM-48	\$8534	QMPM-48SS	\$11,253	48	30	43 ¹ / ₄	115	15.5	1/2	5.1	54.0	410/220
QMPM-72	\$9732	QMPM-72SS	\$14,298	72	30	43 ¹ / ₄	115/115*	15.8/10.4*	3/4	7.9	87.0	610/277

*Electric condensate evaporator requires separate power supply.

MPM/QMPM SERIES Options (QMPM bumper kits are listed on p. 13)

PART NO.	LIST PRICE	DESCRIPTION	SHIP WT. LB/KG
CASTERS			
A075-11140	\$293	Set of 4, 3" dia. for QMPM/MPM-36 and QMPM/MPM-48	17/8
A076-11140	\$429	Set of 6, 3" dia. for QMPM/MPM-72	26/12
SANDWICH RACKS - WELDED WIRE, CHROME PLATED			
33-01450	\$138	16" L for QMPM and MPM models (Max. number of racks per model: -36 size: 2, -48 size: 3, -72 size: 4)	8/4
DIVIDERS FOR SANDWICH RACKS			
33-01452	\$113	All QMPM and MPM models	1/0.5
NIGHT CURTAIN KIT - WHITE (MUST BE FACTORY INSTALLED)			
A071A11131	\$707	For QMPM/MPM-36	10/5
A072A11131	\$719	For QMPM/MPM-48	10/5
A073A11131	\$798	For QMPM/MPM-72	10/5
NIGHT CURTAIN KIT - BLACK (MUST BE FACTORY INSTALLED)			
A071AB1131	\$720	For QMPM/MPM-36	10/5
A072AB1131	\$732	For QMPM/MPM-48	10/5
A073AB1131	\$838	For QMPM/MPM-72	10/5
LIGHT KIT - WHITE (MUST BE FACTORY INSTALLED)			
A071A11151	\$743	For QMPM/MPM-36	15/7
A072A11151	\$749	For QMPM/MPM-48	15/7
A073A11151	\$833	For QMPM/MPM-72	15/7
LIGHT KIT - BLACK (MUST BE FACTORY INSTALLED)			
A071AB1151	\$780	For QMPM/MPM-36	15/7
A072AB1151	\$787	For QMPM/MPM-48	15/7
A073AB1151	\$875	For QMPM/MPM-72	15/7
NIGHT CURTAIN & LIGHT KIT - WHITE (MUST BE FACTORY INSTALLED)			
A071A11141	\$1034	For QMPM/MPM-36	15/7
A072A11141	\$1043	For QMPM/MPM-48	15/7
A073A11141	\$1121	For QMPM/MPM-72	15/7
NIGHT CURTAIN & LIGHT KIT - BLACK (MUST BE FACTORY INSTALLED)			
A071AB1141	\$1085	For QMPM/MPM-36	15/7
A072AB1141	\$1095	For QMPM/MPM-48	15/7
A073AB1141	\$1178	For QMPM/MPM-72	15/7

Open Display Merchandisers

MDT SERIES Multi-deck Open Front Merchandisers



MDT-06



MODEL	LIST PRICE W/O ENDS	DIMENSIONS (In Inches)			CASE AMP DRAW			SHIP CU. FT.	SHIP WT. LB/KG
		L*	D	H	120V	230V			
					LIGHTS	DEF. HEATERS	FANS		
MDT-06	\$12,162	72	37 ¹ / ₂	80 ¹ / ₈	0.5	4.4	0.6	204.0	1135/515
MDT-08	\$15,302	96	37 ¹ / ₂	80 ¹ / ₈	0.5	6.1	0.9	237.0	1230/558

*Total overall length without ends, add 2" for each end.

When ends are ordered with model, they are factory installed and not included in cabinet price.

PART NO. A023-10000 MDT RIGHT HAND END KIT\$834

PART NO. A023-10010 MDT LEFT HAND END KIT\$834

Note: Single units and line-ups require part no. 09-09598 EPR valve (per individual condensing unit requirement). Add \$267 each per EPR valve.

MDT SERIES Options

PART NO.	LIST PRICE	DESCRIPTION	SHIP WT. LB/KG
		LOWER LIGHT ASSEMBLY	
A063-50000	\$580	For MDT-06	30/14
A064-50000	\$648	For MDT-08	35/16
		STAINLESS STEEL KICKPLATE	
A063A11150	\$227	For MDT-06	30/14
A064A11150	\$227	For MDT-08	35/16
		EXTRA SHELVES – WHITE	
A024-01598	\$224	23" X 21 ³ / ₄ " white epoxy-coated solid shelf for both MDT models	*
		EXTRA SHELVES – BLACK PAINTED	
A024-01591	\$241	23" X 21 ³ / ₄ " black epoxy-coated solid shelf for both MDT models	*

*Consult factory.

REMOTE CONDENSING UNIT SPECIFICATIONS AND REFRIGERATION REQUIREMENTS LISTED ON P. 16

MDT models are special order cabinets. Consult factory for availability.

Open Display Merchandisers

REMOTE CONDENSING UNIT SPECIFICATIONS FOR MDT SERIES

(Standard features listed on p. 35)*

Note: Single units and line-ups require part no. 09-09598 EPR valve (per individual condensing unit requirement). Add \$267 each per EPR valve.

MODEL	LIST PRICE	VOLTAGE	REFRIG.	BTU RATING AT +15°F SUCTION +30°F CABINET*	BTU RATING AT -10°F SUCTION 0°F CABINET*	BTU RATING AT -20°F SUCTION -10°F CABINET*	BTU RATING AT -30°F SUCTION -20°F CABINET*	ELECTRICAL		SHIP WT. LB/KG
								MCA	MOP	
MHHX0151B	\$3733	208-230/60/1	R-22	9849	N/A	N/A	N/A	19	25	240/109
MHHX0151C	\$3974	208-230/60/3	R-22	10,097	N/A	N/A	N/A	20	20	240/109
MHHX0191B	\$3853	208-230/60/1	R-22	12,294	N/A	N/A	N/A	23	35	380/173
MHHX0191C	\$4160	200-230/60/3	R-22	11,947	N/A	N/A	N/A	23	25	380/173
MHHX0251B	\$3956	208-230/60/1	R-22	16,246	N/A	N/A	N/A	38	40	400/182
MHHX0251C	\$4083	200-230/60/3	R-22	16,400	N/A	N/A	N/A	23	30	400/182
MHHX0351B	\$4009	208-230/60/1	R-22	22,249	N/A	N/A	N/A	38	50	430/195
MHHX0351C	\$3741	200-230/60/3	R-22	22,766	N/A	N/A	N/A	32	35	430/195
MHHX0441B	\$5052	208-230/60/1	R-22	30,170	N/A	N/A	N/A	45	70	385/175
MHHX0441C	\$4876	200-230/60/3	R-22	30,608	N/A	N/A	N/A	44	45	385/175
MHHX0501B	\$5331	208-230/60/1	R-22	34,686	N/A	N/A	N/A	52	80	530/241
MHHX0501C	\$4792	200-230/60/3	R-22	35,713	N/A	N/A	N/A	44	55	530/241

*BTUs rated at 90°F air entering condenser.

NOTE: Semi-hermetic units and other refrigerants available. Consult factory for details.

REFRIGERATION REQUIREMENTS FOR MDT SERIES

TOTAL OVERALL LENGTH*	MODELS REQUIRED		BTUH SINGLE @15°F SUCTION	BTUH RACK @15°F SUCTION	NORMAL AMBIENT UNIT UP TO 100°F**	HIGH AMBIENT UNIT 100°F TO 120°F**
	MDT-06	MDT-08				
6'0"	1		8500	8250	MHHX0191	MHHX0251
8'0"		1	10,640	10,320	MHHX0191	MHHX0251
12'0"	2		15,960	15,480	MHHX0351	MHHX0441
14'0"	1	1	18,620	18,060	MHHX0441	MHHX0441
16'0"		2	21,000	20,370	MHHX0441	MHHX0501
18'0"	3		23,940	23,220	MHHX0501	MHHX0501
20'0"	2	1	26,600	25,800	MHHX0501	MHHX0501
22'0"	1	2	29,260	28,380	MHHX0501	MHHX0501
24'0"		3	31,920	30,960	MHHX0501	MHHX0501
26'0"	3	1	34,580	33,540	CONSULT FACTORY	
28'0"	2	2	37,240	36,120		
30'0"	1	3	39,900	38,700		

*Total overall length without ends, add 2" for each end.

**Add suffix "B" to indicate single phase unit or "C" to indicate three phase.

NOTE: BTUH load and unit sizes are based on a 75°F, 55% relative humidity (maximum) store.

Ice Merchandisers

IM/IM-24 SERIES Outdoor and Indoor Ice Merchandisers



IM-38

IM-45G

MODEL	LIST PRICE	DIMENSIONS (In Inches)			VOLTS	AMPS	UNIT H.P.	CAPACITY 8 LB. BAGS	SHIP CU. FT.	SHIP WT. LB/KG
		L	D	H						
SOLID DOOR										
IM-38	\$4489	50 ¹ / ₂	35 ¹ / ₂	68 ¹ / ₂	115	5.7	1/4	125	90.3	340/155
IM-60	\$5668	75	35 ¹ / ₂	68 ¹ / ₂	115	7.7	1/3	200	132.1	430/195
SINGLE GLASS DOOR (INDOOR USE ONLY)										
IM-24	\$6006	27 ¹ / ₂	36 ¹ / ₈	77 ⁵ / ₈	115	7.7	1/3	60	79.0	360/164
IM-45G	\$6585	48	30	76 ¹ / ₂	115	9.3	1/3	137	87.2	380/173



IM-24



(For IM-38,
IM-45G &
IM-60)



(For
IM-24)



(For
IM-24)

Glass Door Merchandisers

BMG/BLG SERIES Swing Glass Door Bottom Mounted Merchandisers



BLG-48HD

All models feature labor-saving bare tube condenser coils.



SELF-CONTAINED

MODEL	LIST PRICE	DIMENSIONS (In Inches)			VOLTS	AMPS	UNIT H.P.	CAPACITY CU. FT.	SHIP CU. FT.	SHIP WT. LB/KG
		L	D	H						
MEDIUM TEMP										
BMG-27	\$6842	31	36 ^{3/4}	79	115	8.0	1/3	27.5	79.0	520/236
BMG-48	\$8063	52	36 ^{3/4}	79	115	8.0	1/3	49.0	117.0	755/343
BMG-52	\$9432	56	36 ^{3/4}	79	115	8.0	1/3	53.0	131.0	775/352
BMG-74	\$10,765	78	36 ^{3/4}	79	115	12.0	1/2	75.5	168.0	1025/466
BMG-80	\$11,253	84	36 ^{3/4}	79	115	12.0	1/2	81.6	185.0	1065/484
LOW TEMP										
BLG-27HD	\$9552	31	36 ^{3/4}	79	115	13.9	3/4	27.5	79.0	630/286
BLG-48HD	\$11,950	52	36 ^{3/4}	79	208-230	10.6	1 ^{1/2}	49.0	117.0	880/400
BLG-52HD	\$12,659	56	36 ^{3/4}	79	208-230	10.6	1 ^{1/2}	53.0	128.0	890/405
BLG-74HD	\$14,193	78	36 ^{3/4}	79	208-230	11.1	2	75.5	168.0	1105/502
BLG-80HD	\$15,671	84	36 ^{3/4}	79	208-230	11.1	2	81.6	185.0	1165/530

REMOTE (Less condensing unit)*

MODEL	LIST PRICE	CASE AMP DRAW					STANDARD CONDENSING UNIT*	HEAVY-DUTY CONDENSING UNIT*
		115V		208-230V	230V	DEFROST		
		LIGHTS	EVAP. FANS	CASE HEATER	EVAP. FANS			
MEDIUM TEMP								
BMG-48R	\$6768	1.2	0.5	1.4	N/A	N/A	MHHX0061B	MHHX0081B
BMG-74R	\$8562	1.2	N/A	2.1	0.5	N/A	MHHX0081B	MHHX0111(B or C)
LOW TEMP								
BLG-48R	\$8705	2.1	N/A	6.9	0.5	5.0	MHLZ0071(B or C)	MCLZ0081(B or C)
BLG-74R	\$10,888	2.1	N/A	8.3	0.5	7.0	MHLZ0091(B or C)	MCLZ0101(B or C)

*Remote condensing units sized for 100°F ambient. Consult factory for higher ambient conditions.

BMG and BLG models are also available in quick-connect remote refrigeration options. Please consult factory for pricing and availability.

BLG cabinets (except BLG-27HD) operate on a minimum of 208 volts. Part no. 39-01087 voltage boosting transformer (see options on p. 20) must be used when the supply voltage is less than 208 volts. This transformer is shipped loose.

OPTIONS AND REMOTE CONDENSING UNIT SPECIFICATIONS LISTED ON P. 20

Glass Door Merchandisers

TMG/TLG SERIES Swing Glass Door Top Mounted Merchandisers



TLG-48HD

SELF-CONTAINED

MODEL	LIST PRICE	DIMENSIONS (In Inches)			VOLTS	AMPS	UNIT H.P.	CAPACITY CU. FT.	SHIP CU. FT.	SHIP WT. LB/KG
		L	D	H*						
MEDIUM TEMP										
TMG-27	\$6842	31	35 ³ / ₄	85	115	8.0	1/3	27.5	79.0	490/223
TMG-48	\$8197	52	35 ³ / ₄	85	115	8.0	1/3	49.0	117.0	685/311
TMG-52	\$9432	56	35 ³ / ₄	85	115	8.0	1/3	53.0	128.0	700/318
TMG-74	\$10,470	78	35 ³ / ₄	85	115	12.0	1/2	75.5	168.0	930/423
TMG-80	\$11,253	84	35 ³ / ₄	85	115	12.0	1/2	81.6	185.0	960/436
LOW TEMP										
TLG-27HD	\$10,138	31	35 ³ / ₄	85	115	16.5	3/4	27.5	79.0	600/273
TLG-48HD	\$12,132	52	35 ³ / ₄	85	208-230	11.9	1 ¹ / ₂	49.0	118.7	830/377
TLG-52HD	\$12,659	56	35 ³ / ₄	85	208-230	11.9	1 ¹ / ₂	53.0	128.0	850/386
TLG-74HD	\$15,037	78	35 ³ / ₄	85	208-230	12.4	2	75.5	168.0	1085/493
TLG-80HD	\$15,671	84	35 ³ / ₄	85	208-230	12.4	2	81.6	185.0	1100/500

*Height includes 6"-7" adjustable legs.

TMG & TLG models are special order cabinets. Consult factory for availability.

TLG models feature labor-saving bare tube condenser coils.

REMOTE (Less condensing unit)*

MODEL	LIST PRICE	CASE AMP DRAW					STANDARD CONDENSING UNIT*	HEAVY-DUTY CONDENSING UNIT*
		115V			208-230V	230V		
		LIGHTS	EVAP. FANS	CASE HEATER	EVAP. FANS	DEFROST		
MEDIUM TEMP								
TMG-48R	\$6768	1.2	0.45	4.0	N/A	N/A	MHHX0061B	MHHX0081B
TMG-74R	\$8562	1.2	N/A	4.7	0.5	N/A	MHHX0081B	MHHX0111(B or C)
LOW TEMP								
TLG-48R	\$8874	2.1	N/A	6.4	0.5	5.0	MHLZ0071(B or C)	MCLZ0081(B or C)
TLG-74R	\$11,100	2.1	N/A	8.3	0.5	7.0	MHLZ0091(B or C)	MCLZ0101(B or C)

*Remote condensing units sized for 100°F ambient. Consult factory for higher ambient conditions.

TMG and TLG models are also available in quick-connect remote refrigeration options. Please consult factory for pricing and availability.

TLG cabinets (except TLG-27HD) operate on a minimum of 208 volts. Part no. 39-01087 voltage boosting transformer (see options on p. 20) must be used when the supply voltage is less than 208 volts. This transformer is shipped loose.

OPTIONS AND REMOTE CONDENSING UNIT SPECIFICATIONS LISTED ON P. 20



Glass Door Merchandisers

REMOTE CONDENSING UNIT SPECIFICATIONS FOR BMG/BLG/TMG/TLG SERIES* (Standard features listed on p. 35)

MODEL	LIST PRICE	VOLTAGE	REFRIG.	BTU RATING AT +20°F SUCTION +35°F CABINET*	BTU RATING AT -10°F SUCTION 0°F CABINET*	BTU RATING AT -20°F SUCTION -10°F CABINET*	BTU RATING AT -30°F SUCTION -20°F CABINET*	ELECTRICAL		SHIP WT. LB/KG
								MCA	MOP	
MHHX0061B	\$3009	208-230/60/1	R-22	4826	N/A	N/A	N/A	13	15	230/105
MHHX0081B	\$3157	208-230/60/1	R-22	6010	N/A	N/A	N/A	13	20	240/109
MHHX0111B	\$3158	208-230/60/1	R-22	8119	N/A	N/A	N/A	20	20	170/77
MHHX0111C	\$3269	208-230/60/3	R-22	8272	N/A	N/A	N/A	20	20	170/77
MHLZ0071B	\$3410	208-230/60/1	R-404A	N/A	7988	5938	4032	18	30	250/114
MHLZ0071C	\$3372	200-230/60/3	R-404A	N/A	7717	5722	3962	13	20	250/114
MHLZ0091B	\$4087	208-230/60/1	R-404A	N/A	12,480	9133	6193	27	40	260/118
MHLZ0091C	\$3982	200-230/60/3	R-404A	N/A	12,314	9230	6484	19	25	245/111
MCLZ0081B	\$4936	208-230/60/1	R-404A	N/A	9143	7528	5841	16	25	310/141
MCLZ0081C	\$5048	208-230/60/3	R-404A	N/A	9093	7438	5851	13	15	310/141
MCLZ0101B	\$7281	208-230/60/1	R-404A	N/A	11,804	9104	6999	24	35	330/150
MCLZ0101C	\$6912	208-230/60/3	R-404A	N/A	11,678	8755	6169	19	20	330/150

*BTUs rated at 90°F air entering condenser.

BMG/BLG/TMG/TLG SERIES Options

PART NO.	LIST PRICE	DESCRIPTION	SHIP WT. LB/KG
		BASKETS - CANTILEVER	
A200-16600	\$198	20" x 22" x 5" for BMG/TMG-48, BLG/TLG-48HD, BMG/TMG-74 & BLG/TLG-74HD	10/5
		CASTERS	
A039-11140	\$144	Set of 4, 2" dia. for TMG/BMG-27, BLG-27HD, BMG-48, BLG-48HD, BMG-52 & BLG-52HD	4/2
A044-11140	\$207	Set of 6, 2" dia. for TMG/BMG-74, BLG-74HD, BMG-80 and BLG-80HD	5/2
		LEG KITS FOR BMG/BLG SERIES	
A200-11170	\$430	6" kit for BMG-27, BLG-27HD, BMG-48, BLG-48HD, BMG-52 & BLG 52HD	20/9
A212-11170	\$472	6" kit for BMG-74, BLG-74HD, BMG-80 and BLG-80HD	28/13
		EXTRA CANTILEVER SHELVING	
33-01473	\$111	For BMG/TMG-27 and BLG/TLG-27HD	7/3
33-01474	\$111	For BMG/TMG-48, BLG/TLG-48HD, BMG/TLG-74 and BLG/TLG-74HD	8/4
33-01475	\$111	For BMG/TMG-52, BLG/TLG-52HD, BMG/TMG-80 and BLG/TLG-80HD	8/4
		EXTRA CANTILEVER SHELVING - BLACK PAINTED UPCHARGE	
		\$20 each shelf for all BMG/BLG and TMG/TLG models	
		VOLTAGE BOOSTING TRANSFORMER	
39-01087	\$548	For all BLG and TLG models	14/6

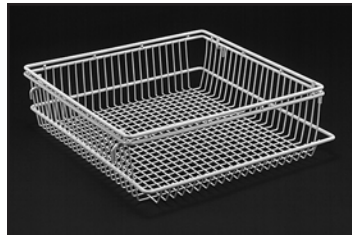

**BMG/BLG & TMG/TLG
CANTILEVER BASKET**

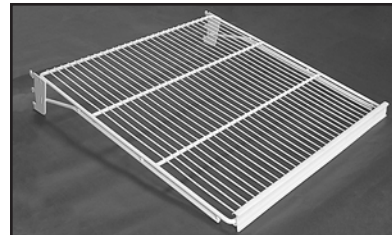

**BMG/BLG & TMG/TLG
CANTILEVER SHELF**

Glass Door Merchandisers

BGR-14 SERIES Bottom Mounted Swing Glass Door Refrigerator



BGR-14



California
Energy
Commission
Certified

MODEL	LIST PRICE	DIMENSIONS (In Inches)			VOLTS	AMPS	UNIT H.P.	CAPACITY CU. FT.	SHIP CU. FT.	SHIP WT. LB/KG
		L	D	H						
BGR-14	\$2141	23 ⁵ / ₈	26 ¹ / ₈	74	115	6.3	1/4	12.3	32.9	200/91

SMB SERIES Sliding Glass Door Merchandisers



SMB-430



MODEL	LIST PRICE	DIMENSIONS (In Inches)			VOLTS	AMPS	UNIT H.P.	CAPACITY CU. FT.	SHIP CU. FT.	SHIP WT. LB/KG
		L	D	H						
SMB-430	\$6950	53	32 ¹ / ₄	76 ¹ / ₂	115	15.0	1/2	43.0	103.0	615/280
SMB-580	\$7738	70	32 ¹ / ₄	76 ¹ / ₂	115	15.0	1/2	58.0	147.0	900/409
SMB-870	\$11,583	102 ³ / ₄	32 ¹ / ₄	76 ¹ / ₂	115	22.5	3/4	87.0	210.0	1115/507

SMB SERIES Options

PART NO.	LIST PRICE	DESCRIPTION	SHIP WT. LB/KG
		CASTERS	
A251-11140	\$332	Set of 4, 3" dia. for SMB-430	25/11
A253-11140	\$432	Set of 6, 3" dia. for SMB-580	34/15
A254-11140	\$432	Set of 6, 3" dia. for SMB-870	36/16
		LOCKS - BARREL TYPE	
35-01474	\$72	For all SMB models	1/0.5
		EXTRA WELDED WIRE, WHITE EPOXY SHELVING	
33-00106	\$111	For SMB-430 and SMB-870	7/3
33-00108	\$111	For SMB-580	7/3
		EXTRA WELDED WIRE SHELVING - BLACK PAINTED UPCHARGE	
		\$20 each shelf for all SMB models	

Endless Remote Glass Door Merchandisers

BEM/BEL SERIES Bottom Mounted Coil Reach-ins



BEL-5-30
(with ends)

BEM & BEL models are special order cabinets. Consult factory for availability.



30" WIDE DOORS

MODEL	LIST PRICE W/O ENDS*	DIMENSIONS (In Inches)			CASE AMP DRAW					SHIP WT. LB/KG
		L**	D	H	120V-1 PHASE			230V-1 PHASE		
					LIGHTS	HEATERS	FANS	FANS	DEFROST	
MEDIUM TEMP										
BEM-2-30	\$9560	62	37 ¹ / ₄	82 ¹ / ₂	1.5	2.1	0.9	N/A	N/A	984/446
BEM-3-30	\$12,351	92 ⁷ / ₁₆	37 ¹ / ₄	82 ¹ / ₂	2.0	3.1	1.4	N/A	N/A	1500/682
BEM-4-30	\$15,091	122 ⁷ / ₈	37 ¹ / ₄	82 ¹ / ₂	2.5	4.0	1.8	N/A	N/A	1920/872
BEM-5-30	\$17,501	153 ⁵ / ₁₆	37 ¹ / ₄	82 ¹ / ₂	3.0	5.0	2.3	N/A	N/A	2340/1064
LOW TEMP										
BEL-2-30	\$10,370	62	37 ¹ / ₄	82 ¹ / ₂	1.5	4.5	N/A	0.5	8.5	1085/493
BEL-3-30	\$12,821	92 ⁷ / ₁₆	37 ¹ / ₄	82 ¹ / ₂	2.0	6.6	N/A	0.7	12.5	1500/682
BEL-4-30	\$16,582	122 ⁷ / ₈	37 ¹ / ₄	82 ¹ / ₂	2.5	8.7	N/A	0.9	16.8	1900/864
BEL-5-30	\$19,113	153 ⁵ / ₁₆	37 ¹ / ₄	82 ¹ / ₂	3.0	10.6	N/A	1.2	20.9	2260/1027

24" WIDE DOORS

MODEL	LIST PRICE W/O ENDS*	DIMENSIONS (In Inches)			CASE AMP DRAW					SHIP WT. LB/KG
		L**	D	H	120V-1 PHASE			230V-1 PHASE		
					LIGHTS	HEATERS	FANS	FANS	DEFROST	
MEDIUM TEMP										
BEM-3-24	\$10,639	72 ³ / ₈	37 ¹ / ₄	82 ¹ / ₂	2.0	2.7	0.9	N/A	N/A	1204/547
BEM-4-24	\$14,125	96 ¹ / ₈	37 ¹ / ₄	82 ¹ / ₂	2.5	3.5	1.4	N/A	N/A	1490/677
BEM-5-24	\$16,117	119 ⁷ / ₈	37 ¹ / ₄	82 ¹ / ₂	3.0	4.3	1.8	N/A	N/A	1760/800
BEM-6-24	\$18,860	143 ⁵ / ₈	37 ¹ / ₄	82 ¹ / ₂	3.4	5.1	2.3	N/A	N/A	2080/945
LOW TEMP										
BEL-3-24	\$11,656	72 ³ / ₈	37 ¹ / ₄	82 ¹ / ₂	2.0	5.6	N/A	0.5	9.9	1150/523
BEL-4-24	\$14,519	96 ¹ / ₈	37 ¹ / ₄	82 ¹ / ₂	2.5	7.4	N/A	0.7	13.1	1520/691
BEL-5-24	\$16,583	119 ⁷ / ₈	37 ¹ / ₄	82 ¹ / ₂	3.0	9.1	N/A	0.9	16.4	1785/811
BEL-6-24	\$19,953	143 ⁵ / ₈	37 ¹ / ₄	82 ¹ / ₂	3.4	10.7	N/A	1.2	19.6	2100/954

*List price includes 5 shelves per door.

**Add 2" to length for each end or insulated partition.

NOTE: Medium temp units furnished with R-22 expansion valve unless otherwise specified. Low temp units furnished with R-404A expansion valve unless otherwise specified.

When ends are ordered, they are factory installed and not included in cabinet price.

PART NO. A148F12000: ONE FACTORY INSTALLED BEM/BEL RIGHT HAND END KIT AND ONE LEFT HAND END KIT.....\$1410

PART NO. A148F12700: ONE FACTORY INSTALLED BEM/BEL RIGHT HAND END KIT\$705

PART NO. A148F12800: ONE FACTORY INSTALLED BEM/BEL LEFT HAND END KIT\$705

OPTIONS LISTED ON P. 24

REMOTE CONDENSING UNIT SPECIFICATIONS LISTED ON P. 25

REQUIRED CONDENSING UNITS LISTED ON P. 26

Endless Remote Glass Door Merchandisers

TEM/TEL SERIES Top Mounted Coil Reach-ins



TEL-5-30
(with ends)

TEM & TEL models are special order cabinets. Consult factory for availability.



30" WIDE DOORS

MODEL	LIST PRICE W/O ENDS	DIMENSIONS (In Inches)			CASE AMP DRAW					SHIP WT. LB/KG
		L*	D	H	120V-1 PHASE			230V-1 PHASE		
					LIGHTS	HEATERS	FANS	FANS	DEFROST	
MEDIUM TEMP										
TEM-2-30	\$9614	63 ¹ / ₂	37 ³ / ₄	80	1.7	2.0	1.0	N/A	N/A	755/343
TEM-3-30	\$11,025	94 ¹ / ₂	37 ³ / ₄	80	3.2	2.6	1.0	N/A	N/A	1435/652
TEM-4-30	\$13,722	124 ¹ / ₂	37 ³ / ₄	80	4.8	3.5	1.4	N/A	N/A	1670/759
TEM-5-30	\$15,534	155	37 ³ / ₄	80	4.8	4.3	1.4	N/A	N/A	2000/909
LOW TEMP (WITH HEAT REFLECTIVE GLASS)										
TEL-2-30	\$9876	63 ¹ / ₂	37 ³ / ₄	80	3.0	3.5	N/A	0.5	5.0	1085/493
TEL-3-30	\$12,520	94 ¹ / ₂	37 ³ / ₄	80	5.2	5.5	N/A	0.5	6.7	1325/602
TEL-4-30	\$15,537	124 ¹ / ₂	37 ³ / ₄	80	5.0	7.3	N/A	0.7	9.5	1915/870
TEL-5-30	\$18,266	155	37 ³ / ₄	80	7.8	9.2	N/A	0.7	12.5	1955/889

24" WIDE DOORS

MODEL	LIST PRICE W/O ENDS	DIMENSIONS (In Inches)			CASE AMP DRAW					SHIP WT. LB/KG
		L*	D	H	120V-1 PHASE			230V-1 PHASE		
					LIGHTS	HEATERS	FANS	FANS	DEFROST	
MEDIUM TEMP										
TEM-3-24	\$10,998	74 ¹ / ₄	37 ³ / ₄	80	2.3	2.3	1.0	N/A	N/A	1325/602
TEM-4-24	\$13,186	98	37 ³ / ₄	80	2.9	3.1	1.0	N/A	N/A	1520/691
TEM-5-24	\$15,179	121 ³ / ₄	37 ³ / ₄	80	3.5	3.3	1.4	N/A	N/A	1720/782
TEM-6-24	\$16,900	145 ¹ / ₂	37 ³ / ₄	80	5.2	4.8	1.4	N/A	N/A	2140/973
LOW TEMP (WITH HEAT REFLECTIVE GLASS)										
TEL-3-24	\$11,283	74 ¹ / ₄	37 ³ / ₄	80	4.0	5.4	N/A	0.5	6.7	1245/566
TEL-4-24	\$13,796	98	37 ³ / ₄	80	5.0	7.3	N/A	0.5	8.0	1300/591
TEL-5-24	\$15,673	121 ³ / ₄	37 ³ / ₄	80	6.0	8.9	N/A	0.7	9.2	1720/782
TEL-6-24	\$17,673	145 ¹ / ₂	37 ³ / ₄	80	8.4	9.4	N/A	0.7	10.1	2140/973

*Add 2" to length for each end or insulated partition.

NOTE: Medium temp units furnished with R-22 expansion valve unless otherwise specified. Low temp units furnished with R-404A expansion valve unless otherwise specified.

When ends are ordered, they are factory installed and not included in cabinet price.

PART NO. A353-10000 FACTORY INSTALLED TEM/TEL RIGHT HAND END KIT..... \$608

PART NO. A353-10010 FACTORY INSTALLED TEM/TEL LEFT HAND END KIT \$608

OPTIONS LISTED ON P. 24

REMOTE CONDENSING UNIT SPECIFICATIONS LISTED ON P. 25

REQUIRED CONDENSING UNITS LISTED ON P. 26

Endless Remote Glass Door Merchandisers

BEM/BEL/TEM/TEL SERIES Options

PART NO.	LIST PRICE	DESCRIPTION	SHIP WT. LB/KG
		PARTITIONS	
A148F20001	\$408	1" insulated partition - to separate condensing units for BEM/BEL models	50/23
A148F30001	\$906	2" insulated partition - multi-temp (adds 2" to overall length) for BEM/BEL models	80/36
A148F40001	\$848	3/8" non-insulated plexiglass partition for BEM/BEL models	40/18
A350-20001	\$363	1" insulated partition - to separate condensing units for TEM/TEL models	50/23
A350-30001	\$790	2" insulated partition - multi-temp (adds 2" to overall length) for TEM/TEL models	100/45
A350-40001	\$815	3/8" non-insulated plexiglass partition for TEM/TEL models	40/18
		STAINLESS STEEL KICKPLATE	
Specify	\$42	20 ga. stainless steel (per linear foot) for BEM/BEL and TEM/TEL models	1/0.5
		CANTILEVER ACCESSORIES - 30" DOORS	
		BASKETS	
A148-16700	\$216	Wire baskets with price tag molding and brackets for BEM/BEL models	7/3
A124-16700	\$188	5.25" deep with integral brackets and price tag molding for TEM/TEL models	7/3
		EXTRA SHELVES	
33-01500	\$114	Wire shelf with price tag molding for BEM/BEL models	4/2
33-01522	\$190	Bottom wire shelf with 2-1/2" raised front lip and price tag molding for BEM/BEL models	5/2
33-01516	\$117	Bottom wire shelf with 5" raised front lip and price tag molding for BEM/BEL models	5/2
A124-16600	\$152	Shelf, brackets and price tag molding for TEM/TEL models	4/2
33-01462	\$148	Bottom shelf with raised front lip and price tag molding for TEM/TEL models	5/2
		CANTILEVER ACCESSORIES - 24" DOORS	
		BASKETS	
A115-16700	\$233	5" deep with integral brackets and price tag molding	7/3
		EXTRA SHELVES	
A115-16600	\$67	Shelf and price tag molding	4/2
A115-16800	\$111	Bottom shelf and price tag molding	5/2
		EXTRA SHELVES - BLACK PAINTED UPCHARGE	
		\$20 each for all BEM/BEL and TEM/TEL models	

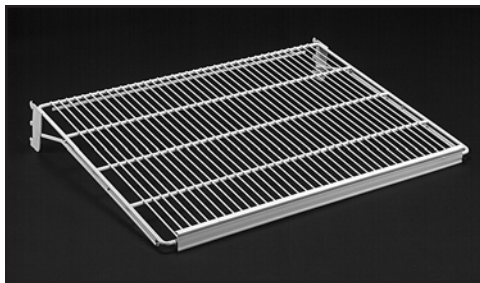

BEM/BEL CANTILEVER SHELF WITH PRICE TAG MOLDING

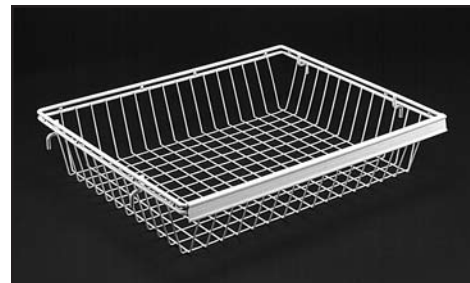

TEM/TEL CANTILEVER BASKET

Endless Remote Glass Door Merchandisers

CONDENSING UNIT SPECIFICATIONS FOR BEM/BEL AND TEM/TEL SERIES (Standard features listed on p. 35)*

MODEL	LIST PRICE	VOLTAGE	REFRIG.	BTU RATING AT +20°F SUCTION* +35°F CABINET*	BTU RATING AT -10°F SUCTION* 0°F CABINET*	BTU RATING AT -20°F SUCTION* -10°F CABINET*	BTU RATING AT -30°F SUCTION* -20°F CABINET*	ELECTRICAL		SHIP WT. LB/KG
								MCA	MOP	
BUILT-UP B-SERIES LOW TEMP SEMI-HERMETIC										
BCLZ0750C	\$15,644	208-230/60/3	R-404A	N/A	46,609	37,322	29,152	55	80	730/332
BCLZ1000C	\$22,451	208-230/60/3	R-404A	N/A	62,719	50,630	39,632	71	100	880/400
BCLZ1500C	\$27,296	208-230/60/3	R-404A	N/A	86,932	70,782	56,305	90	125	990/450
HIGH AMBIENT M-SERIES MEDIUM TEMP HERMETIC										
MHHX0061B	\$3009	208-230/60/1	R-22	4826	N/A	N/A	N/A	13	15	230/105
MHHX0081B	\$3157	208-230/60/1	R-22	6010	N/A	N/A	N/A	13	20	240/109
MHHX0111B	\$3158	208-230/60/1	R-22	8119	N/A	N/A	N/A	20	20	170/77
MHHX0111C	\$3269	208-230/60/3	R-22	8272	N/A	N/A	N/A	20	20	170/77
MHHX0151B	\$3733	208-230/60/1	R-22	11,305	N/A	N/A	N/A	19	25	240/109
MHHX0151C	\$3974	208-230/60/3	R-22	11,534	N/A	N/A	N/A	20	20	240/109
MHHX0191B	\$3853	208-230/60/1	R-22	14,052	N/A	N/A	N/A	23	35	380/173
MHHX0191C	\$4160	200-230/60/3	R-22	13,756	N/A	N/A	N/A	23	25	380/173
MHHX0221B	\$3835	208-230/60/1	R-22	16,081	N/A	N/A	N/A	29	40	380/173
MHHX0221C	\$4065	200-230/60/3	R-22	15,408	N/A	N/A	N/A	29	30	380/173
MHHX0251B	\$3956	208-230/60/1	R-22	18,416	N/A	N/A	N/A	38	40	400/182
MHHX0251C	\$4083	200-230/60/3	R-22	18,251	N/A	N/A	N/A	23	30	400/182
MHHX0301B	\$3895	208-230/60/1	R-22	23,210	N/A	N/A	N/A	38	50	302/137
MHHX0301C	\$3991	200-230/60/3	R-22	23,462	N/A	N/A	N/A	32	40	302/137
MHHX0351B	\$4009	208-230/60/1	R-22	25,139	N/A	N/A	N/A	38	50	430/195
MHHX0351C	\$3741	200-230/60/3	R-22	25,621	N/A	N/A	N/A	32	35	430/195
MHHX0441B	\$5052	208-230/60/1	R-22	34,192	N/A	N/A	N/A	45	70	385/175
MHHX0441C	\$4876	200-230/60/3	R-22	34,476	N/A	N/A	N/A	44	45	385/175
MHHX0501B	\$5331	208-230/60/1	R-22	39,307	N/A	N/A	N/A	52	80	530/241
MHHX0501C	\$4792	200-230/60/3	R-22	40,176	N/A	N/A	N/A	44	55	530/241
HIGH AMBIENT M-SERIES LOW TEMP HERMETIC										
MHLZ0071B	\$3410	208-230/60/1	R-404A	N/A	7988	5938	4032	18	30	250/114
MHLZ0071C	\$3372	200-230/60/3	R-404A	N/A	7717	5722	3962	13	20	250/114
MHLZ0091B	\$4087	208-230/60/1	R-404A	N/A	12,480	9133	6193	26	40	260/118
MHLZ0091C	\$3982	200-230/60/3	R-404A	N/A	12,314	9230	6484	19	25	245/111
MHLZ0121B	\$4279	208-230/60/1	R-404A	N/A	15,035	11,559	8077	30	45	260/118
MHLZ0121C	\$4236	200-230/60/3	R-404A	N/A	14,963	11,596	8402	21	30	260/118
HIGH AMBIENT M-SERIES LOW TEMP SEMI-HERMETIC										
MCLZ0141B**	\$7948	230/60/1	R-404A	N/A	18,139	13,799	9948	28	40	500/227
MCLZ0141C	\$7570	208-230/60/3	R-404A	N/A	18,238	13,903	10,083	26	35	500/227
MCLZ0171B**	\$9868	230/60/1	R-404A	N/A	21,760	16,915	12,434	44	70	510/232
MCLZ0171C	\$9290	208-230/60/3	R-404A	N/A	22,136	17,291	12,822	32	45	510/232
MDLZ0201C	\$8268	208-230/60/3	R-404A	N/A	24,878	19,518	14,838	38	45	530/241
MDLZ0231C	\$8463	208-230/60/3	R-404A	N/A	29,022	22,958	17,605	42	60	530/241
MDLZ0291C	\$10,399	208-230/60/3	R-404A	N/A	36,996	29,187	22,203	47	70	560/255
MDLZ0331C	\$10,953	208-230/60/3	R-404A	N/A	40,682	32,417	25,189	50	70	560/255

*BTUs rated at 90°F air entering condenser.

**Requires part #39-01084 (buck boost transformer) to make supply voltage 230V when only 208V is available.
Add \$1111 for this part (shipped loose).

NOTES:

- M-Series models with 134a and 404A compressors are shipped with P.O.E. oil.
- B-Series models with 404A compressors are shipped with P.O.E. oil.
- Low temp. R-22 units with demand cooling available with Discus compressors only.
- All "M" units include low ambient kit (crankcase heater, head pressure control valve) as standard feature.
- Other voltages and refrigerants available, please consult factory.
- B-Series hermetic low temp models available. Consult factory for details.

Endless Remote Glass Door Merchandisers

REQUIRED CONDENSING UNITS FOR BEM/BEL AND TEM/TEL SERIES (See previous page for unit voltage options and other specifications)

Use this chart to determine the correct condensing unit for your endless lineup.

NO. OF DOORS	+35°F AVERAGE PRODUCT TEMP. +20°F SUCTION 75°F AIR CONDITIONED STORE 55% RELATIVE HUMIDITY			-3°F AVERAGE PRODUCT TEMP. -11°F SUCTION 75°F AIR CONDITIONED STORE 55% RELATIVE HUMIDITY			-12°F AVERAGE PRODUCT TEMP. -18°F SUCTION 75°F AIR CONDITIONED STORE 55% RELATIVE HUMIDITY		
	COND. UNIT REQUIRED FOR AIR TEMP. ENTERING CONDENSER*			COND. UNIT REQUIRED FOR AIR TEMP. ENTERING CONDENSER*			COND. UNIT REQUIRED FOR AIR TEMP. ENTERING CONDENSER*		
	90°F	100°F	110°F	90°F	100°F	110°F	90°F	100°F	110°F
2	MHHX0061B	MHHX0061B	MHHX0061B	MHLZ0071	MHLZ0071	MHLZ0071	MHLZ0091	MHLZ0091	MHLZ0091
3	MHHX0061B	MHHX0061B	MHHX0061B	MHLZ0071	MHLZ0091	MHLZ0091	MHLZ0091	MHLZ0121	MHLZ0121
4	MHHX0061B	MHHX0081B	MHHX0081B	MHLZ0091	MHLZ0091	MHLZ0121	MHLZ0121	MHLZ0121	MHLZ0121
5	MHHX0081B	MHHX0081B	MHHX0111	MHLZ0091	MHLZ0121	MHLZ0121	MHLZ0121	MCLZ0141	MCLZ0171
6	MHHX0111	MHHX0111	MHHX0111	MHLZ0121	MHLZ0121	MCLZ0141	MCLZ0141	MCLZ0171	MDLZ0201
7	MHHX0111	MHHX0111	MHHX0151	MHLZ0121	MCLZ0141	MCLZ0171	MCLZ0171	MDLZ0201	MDLZ0201
8	MHHX0151	MHHX0151	MHHX0151	MCLZ0141	MCLZ0171	MCLZ0171	MDLZ0201	MDLZ0201	MDLZ0231
9	MHHX0151	MHHX0151	MHHX0191	MCLZ0171	MCLZ0171	MDLZ0201	MDLZ0231	MDLZ0231	MDLZ0291
10	MHHX0151	MHHX0191	MHHX0191	MCLZ0171	MDLZ0201	MDLZ0231	MDLZ0231	MDLZ0291	MDLZ0291
11	MHHX0191	MHHX0191	MHHX0221	MDLZ0201	MDLZ0231	MDLZ0231	MDLZ0291	MDLZ0291	MDLZ0331
12	MHHX0191	MHHX0221	MHHX0221	MDLZ0231	MDLZ0231	MDLZ0291	MDLZ0291	MDLZ0291	MDLZ0331
13	MHHX0191	MHHX0221	MHHX0251	MDLZ0231	MDLZ0291	MDLZ0291	MDLZ0291	MDLZ0331	BCLZ0750
14	MHHX0221	MHHX0251	MHHX0251	MDLZ0291	MDLZ0291	MDLZ0291	MDLZ0331	BCLZ0750	BCLZ1000
15	MHHX0251	MHHX0251	MHHX0301	MDLZ0291	MDLZ0291	MDLZ0331	BCLZ0750	BCLZ0750	BCLZ1000
16	MHHX0251	MHHX0251	MHHX0301	MDLZ0291	MDLZ0331	BCLZ0750	BCLZ0750	BCLZ1000	BCLZ1000
17	MHHX0251	MHHX0301	MHHX0351	MDLZ0291	MDLZ0331	BCLZ0750	BCLZ1000	BCLZ1000	BCLZ1000
18	MHHX0301	MHHX0301	MHHX0351	MDLZ0331	BCLZ0750	BCLZ1000	BCLZ1000	BCLZ1000	BCLZ1000
19	MHHX0301	MHHX0351	MHHX0351	BCLZ0750	BCLZ0750	BCLZ1000	BCLZ1000	BCLZ1000	BCLZ1000
20	MHHX0301	MHHX0351	MHHX0441	BCLZ0750	BCLZ1000	BCLZ1000	BCLZ1000	BCLZ1000	BCLZ1500
21	MHHX0351	MHHX0351	MHHX0441	BCLZ0750	BCLZ1000	BCLZ1000	BCLZ1000	BCLZ1000	BCLZ1500
22	MHHX0351	MHHX0441	MHHX0441	BCLZ1000	BCLZ1000	BCLZ1000	BCLZ1000	BCLZ1500	BCLZ1500
23	MHHX0351	MHHX0441	MHHX0441	BCLZ1000	BCLZ1000	BCLZ1000	BCLZ1000	BCLZ1500	BCLZ1500
24	MHHX0441	MHHX0441	MHHX0441	BCLZ1000	BCLZ1000	BCLZ1000	BCLZ1500	BCLZ1500	BCLZ1500
25	MHHX0441	MHHX0441	MHHX0501	BCLZ1000	BCLZ1000	BCLZ1000	BCLZ1500	BCLZ1500	BCLZ1500

*Condensing unit and line size based on 100' line run.

See the *Master-Bilt Condensing Unit & Refrigeration Systems I/O Manual* for other conditions.

For other than Master-Bilt high capacity units, consult our factory.

Deli, Dairy & Sandwich Merchandisers

DMS/DMS-F/DMS-L/DMS-LF SERIES Deli/Display Merchandisers



DMS-48L



All models also classified to NSF standards for food zone requirements.

MODEL	LIST PRICE	DIMENSIONS (In Inches)			VOLTS	AMPS	UNIT H.P.	DISPLAY AREA SQ. FT.	SHIP CU. FT.	SHIP WT. LB/KG
		L	D	H						
HIGH PROFILE										
DMS-48	\$7220	48	29	50 ³ / ₁₆	115	6.0	1/3	19.0	58.0	405/184
DMS-72	\$8438	72	29	50 ³ / ₁₆	115	6.0	1/3	29.0	85.0	535/243
DMS-96	\$10,756	96	29	50 ³ / ₁₆	115	9.1	1/2	39.5	108.0	760/345
LOW PROFILE										
DMS-48L	\$7428	48	29	42	115	6.0	1/3	14.9	58.0	365/166
DMS-72L	\$8685	72	29	42	115	6.0	1/3	22.9	85.0	485/220
DMS-96L	\$10,616	96	29	42	115	9.1	1/2	30.9	108.0	680/309

HIGH PROFILE WITH FRONT SLIDING DOOR

MODEL	LIST PRICE
DMS-48F	\$7606
DMS-72F	\$9008
DMS-96F	\$11,155

LOW PROFILE WITH FRONT SLIDING DOOR

MODEL	LIST PRICE
DMS-48LF	\$7015
DMS-72LF	\$8068
DMS-96LF	\$10,434

DMS models are also available in remote refrigeration options. Please consult factory for pricing and availability.

DMS/DMS-F/DMS-L/DMS-LF SERIES Options

PART NO.	LIST PRICE	DESCRIPTION	SHIP WT. LB/KG
CASTERS			
A039-11140	\$144	Set of 4, 2" diameter for DMS-48, DMS-48F, DMS-48L and DMS-48LF	4/2
A044-11140	\$207	Set of 6, 2" diameter for DMS-72, DMS-72F, DMS-72L, DMS-72LF and DMS-96, DMS-96F, DMS-96L, DMS-96LF	5/2
LEG KITS			
A039-11170	\$143	6" leg kit for DMS-48, DMS-48F, DMS-48L and DMS-48LF	18/8
A044-11170	\$191	6" leg kit for for DMS-72, DMS-72F, DMS-72L, DMS-72LF and DMS-96, DMS-96F, DMS-96L, DMS-96LF	26/12
ICE PANS FOR FRESH FISH AND SEAFOOD			
A282-21000	\$165	Set of two pans and instructions for DMS-48, DMS-48F, DMS-48L and DMS-48LF	14/6
A283-21000	\$234	Set of three pans and instructions for DMS-72, DMS-72F, DMS-72L and DMS-72LF	18/8
A284-21000	\$299	Set of four pans and instructions for DMS-96, DMS-96F, DMS-96L and DMS-96LF	22/10

Milk Coolers

ATMC SERIES Air-Thru Open Front Milk Coolers



ATMC-122SS



MODEL	LIST PRICE	WHITE PAINTED STEEL INTERIOR/ EXTERIOR MODEL	WHITE PAINTED STEEL INTERIOR/ EXTERIOR LIST PRICE	DIMENSIONS (In Inches)			VOLTS	AMPS	UNIT H.P.	CAP. CU. FT.	SHIP CU. FT.	SHIP WT. LB/KG
				L	D	H*						
ATMC-82SS	\$4083	ATMC-82	\$3586	47	33 ¹ / ₈	37	115	4.4	1/5	13.0	43.3	250/114
ATMC-122SS	\$4517	ATMC-122	\$3923	61	33 ¹ / ₈	37	115	5.5	1/4	19.9	55.1	300/136
ATMC-162SS	\$4919	ATMC-162	\$4231	75	33 ¹ / ₈	37	115	5.5	1/4	25.6	67.1	350/159

*Height includes casters.



NSF/ANSI 7

ATMC-D SERIES Air-Thru Dual Access Milk Coolers



ATMC-124DSS



MODEL	LIST PRICE	DIMENSIONS (In Inches)			VOLTS	AMPS	UNIT H.P.	CAPACITY CU. FT.	SHIP CU. FT.	SHIP WT. LB/KG
		L	D	H*						
ATMC-84DSS	\$4391	47	34 ¹ / ₈	37	115	7.1	1/3	13.0	43.3	250/114
ATMC-124DSS	\$4794	61	34 ¹ / ₈	37	115	7.1	1/3	19.9	55.1	300/136
ATMC-164DSS	\$5188	75	34 ¹ / ₈	37	115	7.1	1/3	25.6	67.1	350/159

*Height includes casters.



NSF/ANSI 7

Please note that the warranty on these milk coolers differs from other cabinets in that ATMC and ATMC-D models feature a one year parts, 18 month labor and one year compressor coverage. A four-year extended compressor warranty is optional. See pricing below.

ATMC/ATMC-D SERIES Extended Compressor Warranty

NET PRICE	DESCRIPTION
	FOUR YEAR EXTENDED COMPRESSOR WARRANTY
\$50	Extended compressor warranty for all ATMC-DSS dual access models
\$36	Extended compressor warranty for ATMC-82 and ATMC-82SS
\$39	Extended compressor warranty for ATMC-122, ATMC-122SS, ATMC-162 and ATMC-162SS

OMC SERIES Cold Wall Evaporator Open Front Milk Coolers



OMC-122

MODEL	LIST PRICE	STAINLESS INTERIOR/ EXTERIOR MODEL	STAINLESS INTERIOR/ EXTERIOR LIST PRICE	DIMENSIONS (In Inches)			VOLTS	AMPS	UNIT H.P.	CAP. CU. FT.	SHIP CU. FT.	SHIP WT. LB/KG
				L	D	H*						
OMC-082	\$3823	OMC-082SS	\$4232	35	34	44	115	5.0	1/5	12.2	36.7	326/148
OMC-122	\$4190	OMC-122SS	\$4679	49	34	44	115	5.0	1/5	17.8	49.9	352/160
OMC-162	\$4603	OMC-162SS	\$5091	63	34	44	115	5.0	1/5	23.5	64.0	484/220

*Height includes casters.



DOMC SERIES Cold Wall Evaporator Dual Access Milk Coolers



DOMC-124

MODEL	LIST PRICE	STAINLESS INTERIOR/ EXTERIOR MODEL	STAINLESS INTERIOR/ EXTERIOR LIST PRICE	DIMENSIONS (In Inches)			VOLTS	AMPS	UNIT H.P.	CAP. CU. FT.	SHIP CU. FT.	SHIP WT. LB/KG
				L	D	H*						
DOMC-084	\$5181	DOMC-084SS	\$5378	35	35	44	115	4.1	1/4	12.2	36.7	326/148
DOMC-124	\$5898	DOMC-124SS	\$6109	49	35	44	115	4.8	1/4	17.8	49.9	352/160
DOMC-164	\$6327	DOMC-164SS	\$6823	63	35	44	115	5.7	1/4	23.5	64.0	484/220

*Height includes casters.



OMC/DOMC SERIES Options

PART NO.	LIST PRICE	DESCRIPTION	SHIP WT. LB/KG
		LAMINATE	
02-71126	\$1951	For top, front, sides and back for all OMC and DOMC models	*
		LEGS	
02-71127	\$84	Set of 4 adjustable legs for all OMC and DOMC models	*
		STAINLESS STEEL FLOOR RACK	
02-71123	\$259	For OMC-082/DOMC-084	*
02-71124	\$386	For OMC-122/DOMC-124	*
02-71125	\$517	For OMC-162/DOMC-164	*
		CORNER BUMPERS	
02-71117	\$191	Set of 4 bumpers for all OMC and DOMC models	*

*Consult factory.

Heater/Proofing Cabinet

HP6A-LX SERIES Heater/Proofing Cabinet



HP6A-LX



MODEL	LIST PRICE	DIMENSIONS (In Inches)			VOLTS	HEATING UNIT WATTS	3" LEDGE SPACING (BOTTOM LOAD) PAN CAPACITY		4 1/2" LEDGE SPACING (BOTTOM LOAD) PAN CAPACITY		SHIP CU. FT.	SHIP WT. LB/KG
		L	D	H*			18 x 26 END LOAD	12 x 20 SIDE LOAD	18 x 26 END LOAD	12 x 20 SIDE LOAD		
HP6A-LX	\$3117	26 ³ / ₄	32 ¹ / ₄	71 ³ / ₄	115	1900	17	34	12	24	44.0	180/82

*Height includes casters.

HP6ALX SERIES Options

PART NO.	LIST PRICE	DESCRIPTION	SHIP WT. LB/KG
		LEDGE KIT	
A477-15000	\$607	1 1/2" spaced ledge kit	*

*Consult factory.

Foodservice Reach-ins

TAC/TAF SERIES Top Mounted Foodservice Solid Door Reach-ins



TAC-48HDSA



MODEL	LIST PRICE	DIMENSIONS (In Inches)			VOLTS	AMPS	UNIT H.P.	CAPACITY CU. FT.	SHIP CU. FT.	SHIP WT. LB/KG
		L	D	H*						
MEDIUM TEMP										
TAC-27HDSA	\$8799	31	35 ³ / ₄	80 ¹ / ₂	115	12.1	1/2	25.4	76.0	355/161
TAC-48HDSA	\$11,707	52	35 ³ / ₄	80 ¹ / ₂	115	13.1	1/2	45.9	119.0	465/211
TAC-74HDSA	\$13,337	78	35 ³ / ₄	80 ¹ / ₂	115	15.0	3/4	71.4	174.0	650/295
LOW TEMP										
TAF-27HDSA	\$11,375	31	35 ³ / ₄	80 ¹ / ₂	115	10.5	3/4	25.4	76.0	385/175
TAF-48HDSA	\$13,560	52	35 ³ / ₄	80 ¹ / ₂	115/208-230	5.0/7.5	1	45.9	119.0	540/245
TAF-74HDSA	\$17,634	78	35 ³ / ₄	80 ¹ / ₂	115/208-230	6.2/11.2	1 ¹ / ₂	71.4	174.0	670/305

*Height includes casters.

TAF cabinets (except TAF-27HDSA) operate on a minimum of 208 volts. Part no. 39-01087 voltage boosting transformer (see options below) must be used when the supply voltage is less than 208 volts. This transformer is shipped loose.

All TAC and TAF models are available in remote refrigeration options. Please consult factory for pricing and availability.

TAC/TAF SERIES Options

PART NO.	LIST PRICE	DESCRIPTION	SHIP WT. LB/KG
LEG KITS			
A227-11170	\$124	Leg kit for TAC/TAF-27HDSA and TAC/TAF-48HDSA	20/9
A237-11170	\$184	Leg kit for TAC/TAF-74HDSA	30/14
PAN RACK			
02-70976	\$623	For all TAC/TAF models (per section)	25/11
EXTRA SHELVES - WELDED WIRE, GRAY EPOXY COATED			
33-01455	\$111	For TAC/TAF-27HDSA	4/2
33-01456	\$111	For TAC/TAF-48HDSA and TAC/TAF-74HDSA	4/2
SHELVING CLIPS - 4 REQUIRED PER SHELF			
33-01011	\$4	Clips, each	2/1
VOLTAGE BOOSTING TRANSFORMER			
39-01087	\$548	For TAF-48HDSA and TAF-74HDSA	14/6

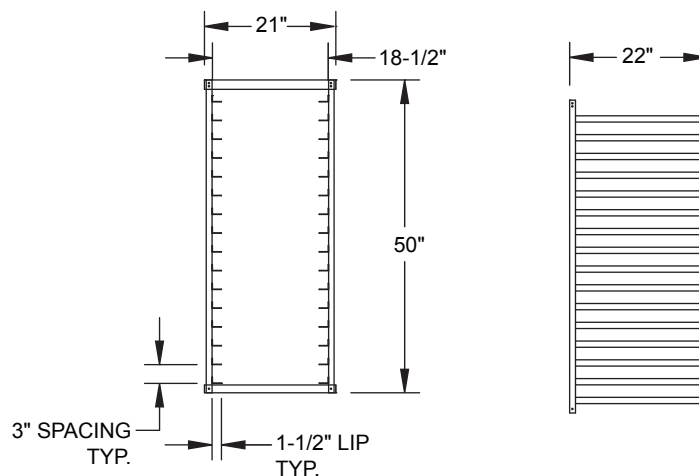

TAC/TAF PAN RACK (ALSO FOR USE IN IHC MODELS)

Foodservice Reach-ins

BSD SERIES Bottom Mounted Solid Door Reach-ins



BSD-52DR



NSF/ANSI 7



California Energy Commission Certified

MODEL	LIST PRICE	DIMENSIONS (In Inches)			VOLTS	AMPS	UNIT H.P.	CAPACITY CU. FT.	SHIP CU. FT.	SHIP WT. LB/KG
		L	D	H*						
REFRIGERATORS										
BSD-24SR	\$4467	27 ⁹ / ₁₆	36 ¹ / ₈	82 ¹ / ₂	115	4.4	1/5	24.0	64.0	365/166
BSD-52DR	\$6640	55 ¹ / ₁₆	36 ¹ / ₈	82 ¹ / ₂	115	6.3	1/4	52.0	115.3	545/248
BSD-80TR	\$8089	82 ⁹ / ₁₆	36 ¹ / ₈	82 ¹ / ₂	115	6.4	1/4	80.0	167.5	750/341
FREEZERS										
BSD-24SF	\$5601	27 ⁹ / ₁₆	36 ¹ / ₈	82 ¹ / ₂	115	9.8	1/2	24.0	64.0	375/170
BSD-52DF	\$8029	55 ¹ / ₁₆	36 ¹ / ₈	82 ¹ / ₂	115	13.9	3/4	52.0	115.3	660/300
BSD-80TF	\$9922	82 ⁹ / ₁₆	36 ¹ / ₈	82 ¹ / ₂	208-230**	8.7	1	80.0	167.5	805/366

*Height includes casters. **208-230/60/1 also requires neutral and safety ground wire.

BSD SERIES Options

PART NO.	LIST PRICE	DESCRIPTION	SHIP WT. LB/KG
		PAN RACK	CONSULT FACTORY
02-71357	\$355	Half set pan rack for BSD models, holds (4) 18" x 26" or (8) 12" x 18" pans	
02-71358	\$709	Full set pan rack for BSD models, holds (8) 18" x 26" or (16) 12" x 18" pans	
		EXTRA SHELVES - WELDED WIRE, GRAY EPOXY COATED WITH SHELF CLIPS	
33-01757	\$108	For BSD-24DR/DF, 28" x 22"	
33-01758	\$108	For BSD-80DR/DF (center shelf), 28" x 27 ¹ / ₂ "	
33-01759	\$108	For BSD-52DR/DF & BSD-80DR/DF (left shelf), 28" x 24 ¹ / ₂ "	
33-01760	\$108	For BSD-52DR/DF & BSD-80DR/DF (right shelf), 28" x 24 ¹ / ₂ "	

COMING SOON



THE NEW VERSION OF BSD SERIES REACH-INS

Prep Units & Undercounters

SPT/UC SERIES Salad/Sandwich Preparation Units, Undercounter Refrigerators And Freezers



SPT-48



UC-72TR



California Energy Commission Certified

UC MODELS ONLY

MODEL	LIST PRICE	DIMENSIONS (In Inches)			VOLTS	AMPS	UNIT H.P.	CAPACITY CU. FT.	SHIP CU. FT.	SHIP WT. LB/KG
		L	D	H*						
SANDWICH/SALAD PREPARATION MODELS										
SPT-28	\$2735	27 ³ / ₄	30	43	115	5.5	1/4	6.5	29.0	198/90
SPT-48	\$3788	48 ¹ / ₄	30	43	115	5.0	1/3	12.0	48.4	264/120
SPT-72	\$5636	72 ³ / ₄	30	43	115	10.8	5/8	19.0	67.7	385/175
UNDERCOUNTER REFRIGERATORS										
UC-28SR	\$2353	27 ³ / ₄	30	36	115	4.0	1/5	6.5	24.8	178/81
UC-48DR	\$3261	48 ¹ / ₄	30	36	115	4.0	1/5	12.0	40.5	244/111
UC-72TR	\$4667	72 ³ / ₄	30	36	115	7.0	1/3	19.0	58.6	340/155
UNDERCOUNTER FREEZERS										
UC-28SF	\$2874	27 ³ / ₄	30	36	115	7.5	1/3	6.5	24.8	190/86
UC-48DF	\$4010	48 ¹ / ₄	30	36	115	11.5	3/5	12.0	40.5	260/118

*Height includes 5" casters.

SPT/UC SERIES Options

PART NO.	LIST PRICE	DESCRIPTION	SHIP WT. LB/KG
LEG KIT			
A039-11170	\$143	Leg kit for all SPT/UC models	20/9
2" DIAMETER CASTERS FOR UC MODELS (REDUCES HEIGHT TO 33¹/₂")			
A039-11140	\$144	For UC-28SR/SF, UC-48SR/SF, UC-72TR	4/2
BACK SPLASH GUARD			
02-70972	\$119	Back splash guard for UC-28SR/SF	5/2
02-70973	\$177	Back splash guard for UC-48DR/DF	7/3
02-71041	\$240	Back splash guard for UC-72TR	*

*Consult factory.

PPT SERIES Pizza Preparation Unit



PPT-67



MODEL	LIST PRICE	DIMENSIONS (In Inches)			VOLTS	AMPS	UNIT H.P.	PAN CAPACITY**	CAP. CU. FT.	SHIP CU. FT.	SHIP WT. LB/KG
		L	D	H*							
PPT-67	\$7238	67	32 ³ / ₈	41 ³ / ₄	115	10.4	5/8	9	20.0	64.2	395/180

*Height includes casters.

**Nine 6" deep polycarbonate pans included with unit.

Sample Cabinet Warranty



908 Hwy. 15 North • New Albany, MS 38652 • 800-647-1284/662-534-9061 • FAX: 800-232-3966
Warranty Parts & Service: 800-684-8988 • FAX: 866-882-7629

LIMITED ONE-YEAR PARTS & LABOR WARRANTY FOR CABINETS, LIMITED ONE-YEAR PARTS & 18-MONTH LABOR WARRANTY FOR ATMC & ATMC-D SERIES MILK COOLERS

Master-Bilt Products (the "Company") warrants to the original purchaser-user that its refrigeration equipment, at the time of delivery, will be free from defects in material and workmanship. Master-Bilt will bear the reasonable and customary labor expense to repair or replace any component part (including said part) found to be defective under the terms and conditions as outlined under Master-Bilt's standard one (1) year parts warranty. Master-Bilt will reimburse said labor expenses to the original purchaser only if after evaluating the original service invoice submitted by the original purchaser-user Master-Bilt determines that this warranty applies. The labor warranty shall apply only to self-contained equipment installed by authorized or approved Master-Bilt dealers, distributors, service companies or refrigeration contractors. The labor warranty does not cover the cost (parts or labor) of installation, start-up, normal maintenance, or normal control adjustment. Your local compressor supplier should exchange the compressor at no charge during first year warranty. Written notice of a claim under this Warranty must be received by the Company within ONE YEAR from the date of installation but no longer than ONE YEAR AND THREE MONTHS from shipment. All claims submitted must have the equipment serial number on the claim.

Any defects caused by misapplication, abnormal use or misuse, lack of or improper maintenance, damage by third parties, alterations, acts of God; failure to follow installation, maintenance or safety instructions or any other event beyond the control of the Company will not be covered under this Warranty.

The obligation of Master-Bilt shall be limited to repairing or replacing (at the option of the Company) any part, which is defective in the reasonable opinion of the Company. The cost of service labor reimbursed will be based on straight-time rate and reasonable time for the repair of the defect.

THIS WARRANTY IS EXCLUSIVE AND IN LIEU OF ALL OTHER WARRANTIES, EXPRESS OR IMPLIED, INCLUDING THE IMPLIED WARRANTIES OF MERCHANTABILITY AND FITNESS FOR A PARTICULAR PURPOSE.

In no event shall the Company be liable for loss of use, revenue or profit or for any other indirect, incidental, special or consequential damages including, but not limited to, food spoilage or product loss.

This warranty shall apply only within the continental United States, its territories and possessions, Canada and Mexico.

EXTENDED FOUR-YEAR COMPRESSOR REPLACEMENT WARRANTY (OPTIONAL ON ATMC & ATMC-D SERIES MILK COOLERS)*

The Company warrants to the original purchaser-user that it will replace the compressor on the Equipment if found, in the reasonable opinion of the Company, to be defective in material or workmanship if written notice is received within five years from date of shipment.

Defective conditions caused by abnormal use or misuse, lack of or improper maintenance, damage by third parties, alterations, acts of God, failure to follow installation, maintenance or safety instructions or any other event beyond the control of the Company will not be covered under this Warranty.

The Compressor Replacement Warranty does not apply to any part of the equipment other than the compressor. The purchaser-user will have the sole responsibility and bear all expenses of removing and returning the defective compressor to the Company as well as the cost of reinstalling the replacement compressor. The Company may satisfy its obligations hereunder by supplying a replacement compressor, which is reasonably similar in design and capacity.

THIS WARRANTY IS EXCLUSIVE AND IN LIEU OF ALL OTHER WARRANTIES, EXPRESS OR IMPLIED, INCLUDING THE IMPLIED WARRANTIES OF MERCHANTABILITY AND FITNESS FOR A PARTICULAR PURPOSE.

In no event shall the Company be liable for loss of use, revenue or profit or for any other indirect, incidental, special or consequential damages including, but not limited to, losses involving food spoilage or product loss.

This Compressor Replacement Warranty shall apply only within the continental United States, its territories and possessions, Canada and Mexico.

REPLACEMENT PART WARRANTY

Master-Bilt warrants to the original purchaser-user that all parts purchased after the first year warranty period will be warranted for 90 days from invoice date.

***CONSULT OUR PRICE LIST FOR PRICING ON THIS OPTION.**

Shipment Date:

SAMPLE

Serial Number:

SAMPLE

Condensing Unit Features

STANDARD COMPONENTS

All components pre-wired and mounted except as noted. Components may vary depending on horsepower and application. Consult our factory for verification of standard and optional components.

Component	Built-up B-Series	High Ambient M-Series
• Liquid line and suction line vibration absorbers (eliminators) for semi-hermetic units only	✓	✓
• Adjustable dual pressure control	✓	
• Head pressure control (flooding valve)	✓	✓
• Preset non-adjustable high pressure control and preset non-adjustable low pressure control		✓ *
• Corrosion-resistant hinged weather hood with lockable snap-down hood latch for easy installation and service access	✓	
• Heavy gauge, galvanized steel mechanically-fastened weather hood		✓
• Suction line filter	✓	
• Heavy-duty 12 gauge galvanized steel legs	✓	
• Heavy-duty angle leg base		✓
• Pre-wired electrical control panel	✓	✓
• Circuit breaker	✓	
• Crankcase heater	✓	✓
• Liquid line filter/drier	✓	✓
• Sight glass	✓	✓
• Liquid and suction line kit with service valve	✓	✓
• Liquid line solenoid valve (shipped loose)	✓	
• Generously-sized condenser	✓	✓
• Large liquid receiver (good for maximum 250 ft. line run, 100 ft. in M-Series units)	✓	✓
• Defrost heater contactor (when required)	✓	✓
• Compressor contactor	✓	✓
• PSC fan motors	✓	✓
• Extended four year limited compressor warranty (optional on ATMC & ATMC-D series milk coolers)	✓	✓
• Defrost timer standard on BEL and TEL series merchandisers	✓	✓
• Solenoid valve(s) standard on MDT, BEM/BEL and TEM/TEL series	✓	✓
• Rotalock suction service valve		✓
• Rifled tubes in condenser to add turbulence		✓
• Liquid line shut-off valve for easy change of filter		✓

*Preset high pressure control and preset low pressure control are non-adjustable in medium temp M-series units. The low pressure control is adjustable in low temp units.

Terms Of Sale

- 1. PRICES.** This list supersedes all other price lists. Master-Bilt reserves the right to change the price of the equipment without notice. All quotations for equipment shall be void if not accepted within 30 days.
- 2. DELIVERY.** Shipping or delivery date is approximate. Seller will not be liable for failure to deliver due to strikes, supplier's delays, changes requested by buyer or any causes beyond Master-Bilt's control.
- 3. SHIPMENTS.** When possible, requested carrier will be used. Master-Bilt, however, reserves the right to ship via any responsible carrier. Shipping charges are payable by consignee and any claims arising as to such charges shall be resolved between the carrier and consignee. All prices are F.O.B. factory.
- 4. HANDLING CHARGES.** Handling charges of \$35.00 are applicable for all cabinets shipped from Master-Bilt off-site warehouses.
- 5. DAMAGE.** Claims for damage in transit must be made by the consignee with the carrier. Master-Bilt assumes no responsibility for damages while in transit.
- 6. TAXES.** Federal, state, city sales or use taxes are not included with these prices.
- 7. CANCELLATIONS/RETURNED GOODS.**
 - A. STOCK ITEMS.** All cancelled orders and returned goods will be assessed a minimum of 25% cancellation or restocking charge. Merchandise may not be returned without written authorization from the Seller. Requests for return must be made within 90 days after shipment. Return authorizations issued are valid for 30 days. Products must be returned in their original factory packaging with freight prepaid. They shall not have been used and must be in the same condition as originally shipped by Master-Bilt.
 - B. NON-STOCK ITEMS.** Orders for custom or modified units cannot be cancelled or returned.
- 8.** All orders not shipped within 60 days of order date are subject to storage charges and/or price increases.
- 9. WARRANTY.** See p. 34 for Master-Bilt warranty details.
- 10.** Possession of price list does not constitute intent to sell.
- 11.** Storage charges are applicable to any cabinet or walk-in that does not ship within two weeks of completion. Charges are calculated at \$25.00 per week per cabinet or, for walk-ins, \$25.00 per week per skid of panels or crated materials.

Special Considerations

- 1. FREIGHT CLASSIFICATIONS.** All cabinets and options (shipped loose) shown in this price list are class 85. Condensing units are class 92.5. **NOTE: Classifications are based on the use of Master-Bilt specified carriers. Third party classifications and rates may vary.**
- 2. 50 CYCLE CABINETS.** Please consult our factory for 50 cycle electrical needs.
- 3. NO UPCHARGE ON MASTER-BILT STANDARD BLACK COLOR FINISH.** Applies to cabinet exterior only on cabinets and merchandisers except for Coldin IG and IG-C models, the BGR-14 model and cabinets with a standard stainless steel finish. Please consult our factory for other special paint requirements.
- 4. OFF-SITE WAREHOUSING.** Shipments of cabinets and step-ins originating from off-site Master-Bilt warehouses will include a \$35.00 handling fee per piece plus applicable freight/associated fees.
- 5. STORAGE CHARGES.** Completed orders placed on shipping hold are subject to a storage charge of \$25.00 per piece per week.
- 6. MINIMUM INVOICE AMOUNT.** A minimum invoice of \$40.00 applies to all orders.
- 7. CREDIT CARDS ACCEPTED.** Master-Bilt proudly accepts the following:



Contact Directory

Please contact us at the numbers below for assistance.

SALES & CUSTOMER SERVICE	Phone: 800-647-1284 or 662-534-9061 Fax: 800-232-3966 or 662-534-6049 E-mail: sales@master-bilt.com
WARRANTY PARTS & TECHNICAL SERVICE	Phone: 800-684-8988 or 662-534-9061 Fax: 866-882-7629 E-mail: service@master-bilt.com
PARTS SALES	Heritage Food Service Equipment Phone: 800-458-5593 or 260-482-1444 Fax: 800-800-4981 or 260-482-4542 E-mail: master-biltinfo@hfse.com
CREDIT	Phone: 662-539-4310 Fax: 662-539-3961 E-mail: credit@master-bilt.com
LITERATURE REQUESTS	Phone: 800-647-1284 or 662-534-9061 Fax: 800-232-3966 or 662-534-6049 E-mail: info@master-bilt.com
WEBSITE	www.master-bilt.com

**For the latest product information and specifications go to
www.master-bilt.com/products/products.htm**

Our equipment is featured in





All Non-Warranty Parts Distributed By



Phone: 800-458-5593/260-482-1444

Fax: 800-800-4981/260-482-4542

E-mail: master-biltinfo@hfse.com

For the latest product information and specifications go to www.master-bilt.com/products/products.htm.



908 Highway 15 North • New Albany, MS 38652
Phone: 800-647-1284 • Fax: 800-232-3966
www.master-bilt.com



Due to continuous product enhancements, we reserve the right to change specifications without notice.

1217-7/08 ©Master-Bilt Products division of Standex International, Inc. All rights reserved. Printed in USA.